

UV INKJET PRINTER

UJV200-130 / 160

Operation Manual

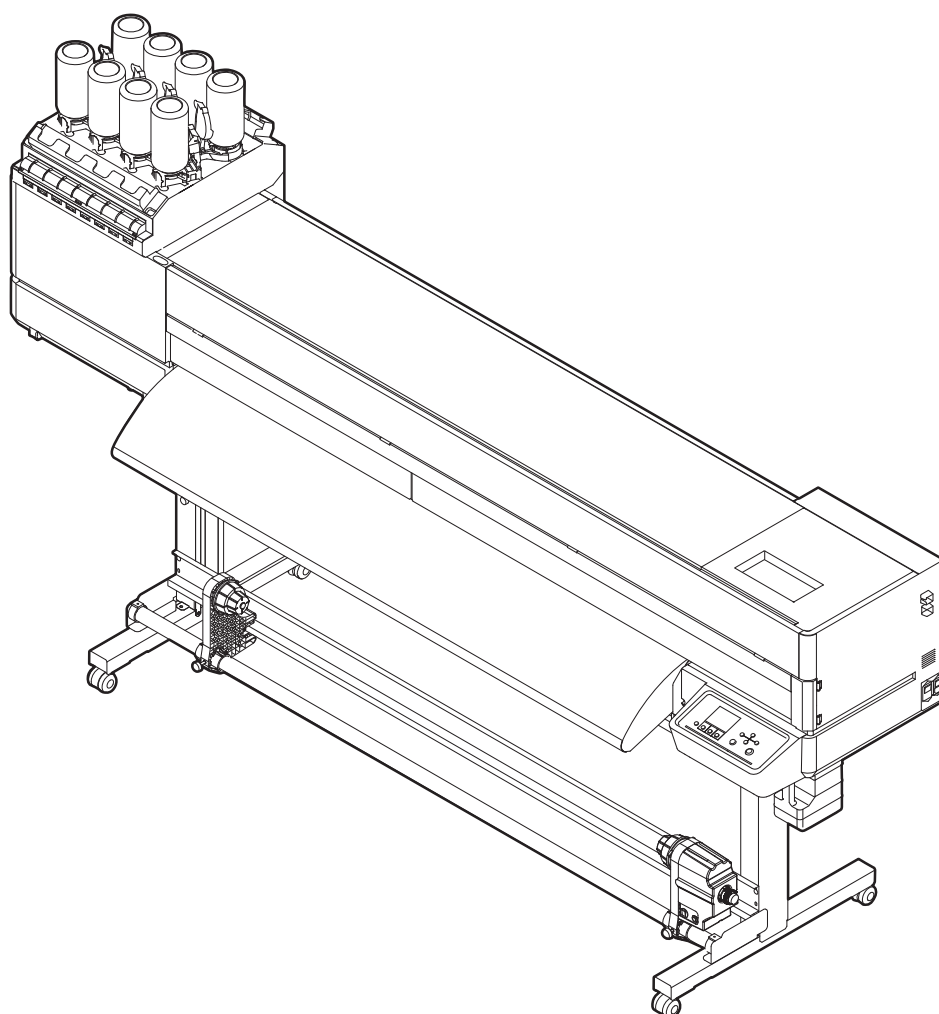

You can also download the latest manual from official website.

MIMAKI ENGINEERING CO., LTD.

<https://mimaki.com/>

D203918-11

Original instructions

Operation Manual

TABLE OF CONTENTS

Introduction	5
To Ensure Safe Use	7
Symbols	7
Usage Precautions	8
Notes on Handling Ink or any Other Liquid Used with the Machine	12
Ink Specifications	14
Restrictions Concerning the Expiration Date of Ink Used in the Machine	15
Installation Precautions.....	16
Installation Space	17
When relocating the machine	17
Safety Interlocks	18
Warning Label.....	19

Chapter 1 Before Use

1.1 Part Names and Functions	24
Front	24
Rear and Right Side View.....	25
Carriage	26
Station.....	26
Platen.....	26
Pinch Rollers and Grit Rollers.....	27
Media Sensor.....	27
Power Supply Switch	28
Operating Panel	29
1.2 Connecting the Power Cable	32
Turning On the Power.....	32
Turning Off the Power.....	33
1.3 Connecting a PC to the Product	35
Using a LAN Cable	35
Using a USB Cable.....	36
1.4 System Configuration	37
Installing the Mimaki Driver.....	38
Installing RIP Software	38
Obtaining Color Profiles	38
Setting Up RIP Software.....	38
1.5 Ink Replacement Method.....	40
Messages informing the user of the ink levels.....	40
Replacing Ink	41

Chapter 2 Printing

2.1 Print Process	48
2.2 Adjusting Print Head Height.....	51

2.3 Loading the Media	52
Media	52
Take-up unit	53
Feeding unit	55
Loading the Roll Media	57
Registering the Media	62
2.4 Setting the Heater Temperature	64
2.5 Test Printing	65
Changing the Layout Direction for Test Printing	65
Checking White Ink Ejection	66
Ejection Failures	66
2.6 Head Cleaning	67
2.7 Auto Correction	68
2.8 Feed Correction	69
Feed Correction Procedure	69
2.9 Correcting the Drop Position	71
Drop Position Correction Procedure	71
2.10 Preparing RIP data	73
2.11 Printing	75
Changing the origin	75
Starting Printing	76
Stopping Printing (Data Clear)	77
2.12 Cutting the media	78

Chapter 3 Setup

3.1 Media Setting Menu	80
3.2 Maintenance Menu	83
Registering Nozzle Recovery Manually	86
Nozzle Check (Option)	86
3.3 Function Setting Menu	87
3.4 Environment Setting Menu	89
3.5 Machine Status Menu	90

Chapter 4 Maintenance

4.1 Maintenance Precautions	92
-----------------------------------	----

4.2 Maintenance Methods	93
Maintenance Items and Timing.....	93
Ink Maintenance	94
Cap Rubber Cleaning	94
Carriage Underside Cleaning	95
Cloth Wiper Area Cleaning	96
NCU (Option) Cleaning.....	97
DAS (automatic correction function) / Sheet width sensor cleaning ...	98
Ink Discharge Channel Cleaning	99
Media Sensor Cleaning	99
Media Cutter Cleaning	100
Media Holder Cleaning	101
Jam Sensor Detecting Plate Cleaning	102
Platen Cleaning	102
Cover (Exterior) Cleaning	103
When this Printer is Left Unused for a Long Time	103
4.3 Replacement of Consumable Item	105
Consumable Item Replacement Timing.....	105
Cloth Wiper Replacement.....	106
Cap Replacement	109
Replacing the Absorber Around the Station	111
Media Holder Replacement	112
Media Cutter Replacement	114
Waste Ink Tank Replacement.....	115
Ink bottle cap replacement.....	118

Chapter 5 Troubleshooting

5.1 Troubleshooting	120
The power does not turn on.....	120
Printing is not possible.....	120
The media jams or the media is dirty.....	120
Image defects occur.	121
The heater temperature does not rise to the specified value.....	125
The ink has leaked out.....	125
The light-blocking cover comes off.	125
Abnormal noise occurs during cleaning.....	126
5.2 Problems Causing Messages to Appear	127
Warning Messages	127
Ink error	130
Error Message	131
SYSTEM HALT	138

Chapter 6 Appendix

6.1 Specifications.....	140
6.2 LICENSE Library	143

Introduction

Thank you for purchasing the Inkjet printer UJV200 series.

Read this operating manual ("this document" hereinafter) thoroughly and make sure you understand its contents to ensure safe and correct use of the product.

Please note that the illustrations contained in this manual are intended to show functions, procedures, or operations and may sometimes differ slightly from the actual machine.

Adobe, the Adobe logo, Acrobat, Illustrator, Photoshop, and PostScript are the trademarks or registered trademarks of Adobe Incorporated in the United States and other countries.

Other company and product names mentioned herein are the trademarks or registered trademarks of the respective companies in Japan and in other countries.

Unauthorized reproduction of any portion of this document is strictly prohibited.

© 2026 MIMAKI ENGINEERING Co., Ltd.

● DISCLAIMERS

- MIMAKI ENGINEERING REJECTS ALL LIABILITY FOR DAMAGE ARISING DIRECTLY OR INDIRECTLY FROM THE USE OF THE UJV200 series ("THIS MACHINE" HEREINAFTER), WHETHER OR NOT THE PRODUCT IS FAULTY.
- MIMAKI ENGINEERING REJECTS ALL LIABILITY FOR DAMAGE, DIRECT OR INDIRECT, TO MATERIALS CREATED WHILE USING THIS MACHINE.
- USING THIS MACHINE IN CONJUNCTION WITH DEVICES OTHER THAN THOSE RECOMMENDED BY MIMAKI ENGINEERING MAY RESULT IN FIRE OR ACCIDENTS. SUCH INCIDENTS ARE NOT COVERED BY THE PRODUCT WARRANTY. MIMAKI ENGINEERING REJECTS ALL LIABILITY FOR DAMAGE, DIRECT OR INDIRECT, ARISING FROM SUCH INCIDENTS.
- USE ONLY GENUINE MIMAKI ENGINEERING INK AND MAINTENANCE LIQUID. USE OF OTHER PRODUCTS MAY RESULT IN FAILURES OR REDUCE PRINT QUALITY. SUCH INCIDENTS ARE NOT COVERED BY THE PRODUCT WARRANTY. MIMAKI ENGINEERING REJECTS ALL LIABILITY FOR DAMAGE, DIRECT OR INDIRECT, ARISING FROM SUCH INCIDENTS.
- DO NOT ATTEMPT TO REFILL THE INK BOTTLES WITH UNAUTHORIZED INK. SUCH INCIDENTS ARE NOT COVERED BY THE PRODUCT WARRANTY. MIMAKI ENGINEERING REJECTS ALL LIABILITY FOR DAMAGE, DIRECT OR INDIRECT, ARISING FROM SUCH INCIDENTS.
- AVOID USING UV-LED UNITS OR UV POWER SUPPLY UNITS OTHER THAN THOSE SPECIFIED BY MIMAKI ENGINEERING. USING DEVICES OTHER THAN GENUINE MIMAKI ENGINEERING DEVICES MAY RESULT IN FAILURE, ELECTRIC SHOCK, OR FIRE. SUCH INCIDENTS ARE NOT COVERED BY THE PRODUCT WARRANTY. MIMAKI ENGINEERING REJECTS ALL LIABILITY FOR DAMAGE, DIRECT OR INDIRECT, ARISING FROM SUCH INCIDENTS.

● TV and radio interference



- The machine emits high-frequency electromagnetic radiation while operating. Under certain circumstances, this may result in TV or radio interference. We make no guarantee that this machine will not affect special radio or TV equipment.

If radio or TV interference occurs, check the radio or TV reception after turning off the machine. If the interference disappears when the power is turned off, the machine is likely to be the cause of the interference.

Try any of the following solutions or combinations of these solutions:

- Change the orientation of the TV or radio antenna to find a position where interference does not occur.
- Move the TV or radio away from this machine.
- Plug the TV or radio into a power outlet on a power circuit other than the power circuit to which this machine is connected.

● FCC (Federal Communications Commission) regulations

The machine has been tested and certified to comply with restrictions applying to Class A digital devices under Part 15 of the FCC regulations. These restrictions are designed to provide suitable protection from harmful interference when the printer is used in commercial environments.

This product may generate, use, or emit radio frequency energy and may cause harmful interference with radio communications if not installed or used in accordance with the operating manual.

Use of this product in residential areas may cause harmful interference. If so, the user is responsible for rectifying such interference.











- Use only the cables recommended by Mimaki Engineering when connecting to the machine. Use of other cables may cause the product to exceed the restrictions stipulated by FCC regulations. To maintain compliance with FCC regulations, use the cables recommended by Mimaki Engineering.
-

To Ensure Safe Use

Symbols

In this manual, symbols indicate and explain precautions. Make sure you fully understand the meaning of each symbol and use the machine safely and correctly.

Explanation		
	Warning	Indicates a potential hazard that may result in death or serious injury if handled improperly or if instructions are disregarded.
	Caution	Indicates a potential hazard that may result in minor or moderate injury if handled improperly or if instructions are disregarded.
	Notice	Indicates a potential hazard that may result in property damage if handled improperly or if instructions are disregarded.
	Warning sign	Indicates something that requires attention. Warning specifics are drawn inside the symbol.
	Mandatory action sign	Indicates an action that must be carried out. The specifics of the mandatory action are drawn inside the symbol.
	Prohibition sign	Indicates a prohibited action. The specifics of the prohibited action are drawn inside the symbol.
	Important	Indicates important information related to use of this machine.
	Tip	Indicates useful reference information.
	Reference information	Indicates the corresponding page for related information.

Usage Precautions

● In the event of abnormal conditions

WARNING



- In the event of abnormal conditions such as smoke or unusual odor, turn off the main power immediately and unplug the power cable. Continuing to use the machine under these conditions may result in failure, electric shock, or fire. Once you have confirmed that smoke is no longer being emitted, contact your local dealer or our service office. Never attempt to repair the machine yourself, which is hazardous.

CAUTION



- Immediately wipe off any ink, maintenance liquid, waste ink, or other liquid used with the product that comes into contact with your skin. Then wash using soap, and rinse with plenty of water. Failure to wash off ink may result in skin inflammation. If your skin becomes irritated or painful, seek medical attention immediately.
- If ink, maintenance liquid, waste ink, or any other liquid used in the product comes into contact with your eyes, rinse immediately with plenty of clean water. Rinse for at least 15 minutes. If you wear contact lenses and they can be easily removed, remove after rinsing for at least 15 minutes with clean water. Be sure to also rinse the undersides of your eyelids. Failure to rinse off ink may result in blindness or impaired vision. If your eyes become irritated or painful, seek medical attention immediately.
- If ink, maintenance liquid, waste ink, or any other liquid used in the product enters your mouth or is swallowed, gargle with water immediately. Do not induce vomiting. Seek medical attention promptly. Inducing vomiting may cause liquid to enter the airway.
- If a large amount of vapor is inhaled, move to a well-ventilated area, keep warm, and rest in a posture that allows easy breathing. If the condition does not improve, seek medical attention promptly.

NOTICE



- If an ink leak occurs, turn off the main power immediately and unplug the power cable. Then, contact your local dealer or our service office.

● Power supply precautions

⚠ WARNING



- Use the power cable provided. Otherwise there is a risk of failure, electric shock, or fire. The power cable provided is exclusive for the machine, and must not be used for other electrical equipment.
- Always hold the plug when removing the power cable. Pulling out the power cable may damage the cable, leading to failure, electric shock, or fire.
- Do not use the machine with dust accumulated on the power plug. Otherwise there is a risk of failure, electric shock, or fire.
- Take care to prevent metals from touching the power plug blades. Otherwise there is a risk of failure, electric shock, or fire.
- Do not damage or modify the power cable. Do not place heavy objects on, heat or stretch it. Doing so may damage the cable, leading to electric shock or fire.
- Do not use extension cords or power strips. Otherwise there is a risk of failure, electric shock, or fire.
- Do not use the power cable if it is damaged or broken or if the core wire is exposed. Otherwise there is a risk of failure, electric shock, or fire.
- Do not handle the power plug with wet hands. Disregarding this precaution may result in electric shock.



- Plug the power cable plug into a grounded power outlet. Otherwise there is a risk of failure, electric shock, or fire.
- When installing electrical outlets, perform grounding work to prevent electric shock. All electrical work (Class C grounding work; formerly Type 3 grounding work) must be handled by a licensed electrician.

NOTICE



- Do not turn off the main power supply. Turning off the main power supply will disable the automatic maintenance function (including nozzle clogging prevention function and ink discharge channel cleaning function). This increases the risk of ejection failures (such as nozzle clogging or deflection).

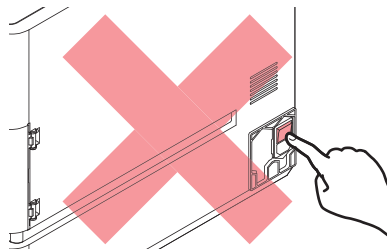

- Use the machine with a power supply that meets specifications.
- Be sure to plug the power cable into a power outlet close to the machine. Insert the power plug blade securely.
- When connecting the power cable, check the input voltage of the power outlet and the capacity of the breaker. Also, connect each cable to a separate power source with an independent breaker. Connecting to power outlets linked with the same breaker will cause the breaker to trip.

● **Caution regarding moving parts**

 **CAUTION**



- Keep parts of the body such as the face and hands away from moving parts. Also keep clothing (e.g., loose clothing and accessories) that may impede work away from the machine. Failure to do so may result in injury.



- Long hair should be tied back. Failure to do so may result in injury.

● **Do not disassemble or repair**

 **WARNING**



- Do not attempt to disassemble or repair this machine. Otherwise there is a risk of failure, electric shock, or fire.

● **Heater**

 **CAUTION**



- The heater becomes extremely hot. Do not touch with bare hands.

NOTICE

● **Ultraviolet light (UV) and the UV-LED unit**

 **WARNING**



- Do not place combustibles under the UV-LED unit, and do not cover it with paper or cloth. There is a risk of fire or burns.
- Small amounts of ultraviolet light may leak from the UV-LED unit. Wear UV safety glasses, Interface shields, masks, gloves, and long-sleeved clothing to protect the eyes and skin from ultraviolet light.
 - (1) Exposure to ultraviolet light may result in skin inflammation. Even if no inflammation occurs, extended or repeated exposure may lead to chronic problems.
 - Acute problems: Inflammation
 - Chronic problems: Skin cancer, wrinkles, blotches
 - (2) Looking directly at the lamp while the lamp is on may result in eye pain or damage to eyesight. Even if no eye pain occurs, extended or repeated exposure may lead to chronic problems.
 - Acute problems: Ultraviolet keratitis, conjunctivitis, discomfort, pain, watery eyes
 - Chronic problems: Pterygium, cataracts

 **CAUTION**



- The UV-LED unit becomes extremely hot. Be careful not to touch the LED after it has been turned off until it has sufficiently cooled.



- Do not expose the skin or eyes directly or indirectly to light from the UV-LED unit. The UV-LED unit emits ultraviolet (UV) light. Skin or eye exposure may result in inflammation.



- Be sure to use the UV safety glasses provided. May cause eye pain and vision problems.

NOTICE



- Avoid scratching or subjecting the UV-LED unit to excessive force. Disregarding this precaution may result in deformation or failure of the unit.
- Avoid touching the glass on the underside of the UV-LED unit with bare hands. Disregarding this precaution may impair UV ink curing. If the glass becomes dirty, wipe clean using a soft, clean cloth soaked with ethanol. Be careful to keep ethanol from splashing on the covers or other parts while cleaning. Disregarding this precaution may result in deformation or failure of the unit.

● Other usage precautions

⚠ WARNING



- Keep children away from the machine.

NOTICE



- Do not pull the media when the clamp lever is lowered (the media is clamped). Doing so may damage the machine.



- The underside of the media may be soiled depending on how the printed media has been stored (due to weight when laying printed media rolls horizontally, for example) and the media type. Perform a test beforehand to check that the media does not transfer ink to the underside of the adjacent media.

● Disposing of the product

⚠ CAUTION



- Please contact your local retailer or service agent.
- When disposing of the product yourself, contact an industrial waste disposal operator or dispose of the product in accordance with local laws and regulations.

Notes on Handling Ink or any Other Liquid Used with the Machine

Precautions regarding ink, maintenance liquid, or other liquids used with this machine are included with the containers. Thoroughly read them and make sure you understand the contents.



- Be sure to read the safety data sheet (SDS) before use. <https://mimaki.com/supply/sds/>

CAUTION



- Pay close attention to ventilation and be sure to wear safety glasses, gloves, and a mask when handling ink, maintenance liquid, waste ink, or other solutions used with the machine. Leaking ink may adhere to the skin or get into the eyes or mouth.



- Do not subject cases containing ink to strong shock or violent shaking. Do not attempt to refill the ink. Leaking ink may adhere to the skin or get into your eyes or mouth.



- Do not disassemble cases containing ink. Leaking ink may adhere to the skin or get into your eyes or mouth.



- Do not store ink, maintenance liquid, or other liquids used with the machine in locations where children may enter.



- When disposing of ink, maintenance liquid or other liquid used with the product, or containers or non-woven fabric contaminated with ink or other liquid, contact an industrial waste disposal operator or dispose of the product in accordance with the local laws and regulations.

NOTICE



- Do not store ink, maintenance liquid, or other liquids used with the machine in locations exposed to direct sunlight.
- Do not store ink, maintenance liquid, or other liquids used with the machine in environments where cutting fluid or other volatile substances (such as amines or modified amine alcohol) are present in significant quantities. Storage in such places increases the risk of failure or ejection failures (e.g., nozzle clogging or deflection).
- Do not use ink, maintenance liquid, or other liquids used with this machine with other printers. Doing so may cause failure.



- Be sure to store them in a low place no higher than 1 m above the floor. Otherwise there is a risk of scattering if the containers fall.
- Store in tightly sealed containers.
- Store in a cool, dark place.
 - (1) Store ink in a place where ink does not freeze. Using defrosted ink may deteriorate ink constituents and reduce print quality.
 - (2) When ink is moved from a cold place to a warm place, leave it in the environment where the machine is installed for at least three hours before using it.
 - (3) Open the container just before installing it, and use it up as quickly as possible. If it is opened and left for an extended period of time, print quality may be reduced.



- Do not touch the metal parts of the ink IC chip. Static electricity may damage the ink IC chip, and dirt or damage may cause the ink IC chip read error.



- Printing is not possible when different types of ink IC chips are used.
- If the ink bottle mounted on the machine is dented, it may still be used.

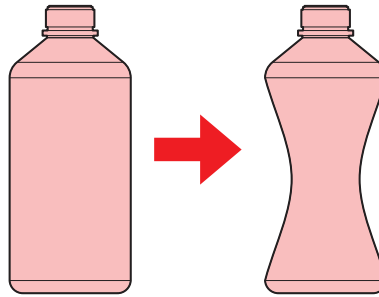

Ink Specifications

Item		Details
Type		Special UV curing ink (Mimaki Engineering product)
Color ^{*1}		Cyan (C) Magenta (M) Yellow (Y) Black (K) White (W) Clear ink (CI)
Form		Bottle
Ink capacity ^{*1}		1000 ml
Expiration date		As indicated on the ink bottle. However, after opening, it should be consumed within three months, even if before the expiration date.
Storage temperature	When stored	5 to 30 °C (daily mean temperature) <ul style="list-style-type: none"> • However, not more than 1 month at 30 °C • Ink quality may deteriorate if stored outside these conditions.
	During transportation	1 to 60 °C <ul style="list-style-type: none"> • However, not more than 120 hours at 60 °C, and not more than 1 month at 40 °C • Where possible, avoid storing in cold locations below 0 °C and hot locations above 40 °C. • Ink quality may deteriorate if stored outside these conditions.

*1. Depending on ink type

Restrictions Concerning the Expiration Date of Ink Used in the Machine

Example: When the expiration date is April 20xx

- May 20xx: Replace with new ink or use up as quickly as possible. Printing is possible.
- June 20xx: Replace with new ink or use up as quickly as possible. Printing is possible.
- July 20xx: Printing is not possible.



- The message appears on the display.



- The ink expiration date is indicated on the ink container. Expired ink may cause ejection failures or alter the color tone. Printing is possible even if the ink has passed its expiration date. Nevertheless, we recommend replacing with new ink or using up as quickly as possible.
-

Installation Precautions

WARNING



- Do not install the machine in a place close to fire.
- Do not place flower vases, pots, cups, containers containing cosmetics, chemicals or water, or small metal items on or close to the machine. If they enter the machine, there is a risk of failure, electric shock, or fire.



- Do not install this machine in humid locations or locations where it may be exposed to splashing water. Otherwise there is a risk of failure, electric shock, or fire.



- Do not install the machine in a place where children may enter.



- When disabling safety functions (such as interlocks) during installation or maintenance, be sure to check and follow all warning instructions described in each procedure beforehand. Improper handling may result in serious personal injury.

CAUTION



- A ventilation system must be provided if the machine is installed in a poorly ventilated area or sealed room.
- Be sure to observe the following points regarding exhaust port installation:
 - (1) Exhaust port installation must conform to local environmental, health, and safety (EHS) guidelines.
 - (2) If the exhaust port is fitted with a shutoff valve, the valve must be open when the machine is in use.

NOTICE



- Do not install the machine in a dusty location. Dust ingress inside the machine increases the risk of failure or ejection failures (e.g., nozzle clogging or deflection).
- Do not install the machine where it is exposed to drafts, such as near an air conditioner. This increases the risk of dust ingress inside the machine.
- Do not install the machine in unstable locations or locations subject to vibration. This increases the risk of failure or ejection failures (such as nozzle clogging or deflection).
- Do not install the machine in a location subject to direct sunlight.
- Do not install the machine in a location subject to extreme temperature fluctuations. This increases the risk of failure or ejection failures (such as nozzle clogging or deflection).
- Do not install the machine in a location where large equipment generating noise is situated.
- Do not install the machine in locations where photographic fixing agent vapors, acid fumes (such as acetic acid or hydrochloric acid), cutting fluid, or other volatile substances (such as amines or modified amine alcohol) are present. Installing in such environments increases the risk of ink solidifying on the print head surface, causing failure or ejection failures (e.g., nozzle clogging or deflection).



- Operating environment: 20 to 30 °C (68 to 86 °F), 35 to 65 %RH (no condensation)
- Temperature range in which accuracy is guaranteed: 20 to 25 °C (68 to 77 °F)

Installation Space

Provide the following space around the machine to allow safe and proper replacement of ink and media:

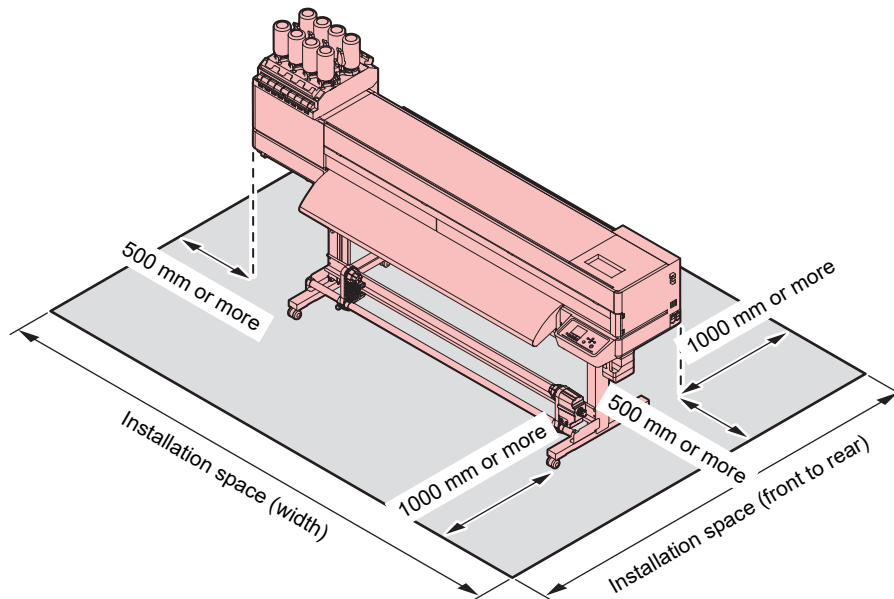

Size	130	160
Width ^{*1}	At least 3,520 mm (2,520 mm)	At least 3,770 mm (2,770 mm)
Depth ^{*1}	At least 2,748 mm (748 mm)	
Height ^{*1}	(1,405 mm)	
Weight	(155kg)	(160kg)

*1. The figures in parentheses indicate machine dimensions excluding ink bottles.

When relocating the machine

Contact your local dealer or our service office. There is a risk of failure or damage to the machine if you try to move it yourself.

Safety Interlocks

The machine is equipped with interlocks to ensure safety during use.

Printing will abort if you open the covers while printing is underway. The RIP data will need to be resent.

- Safety interlock locations

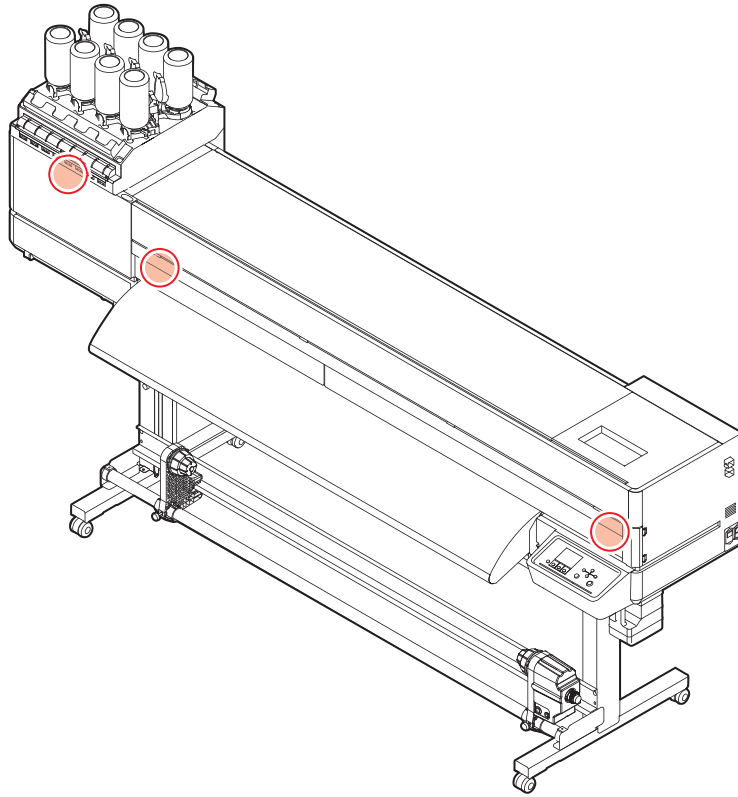







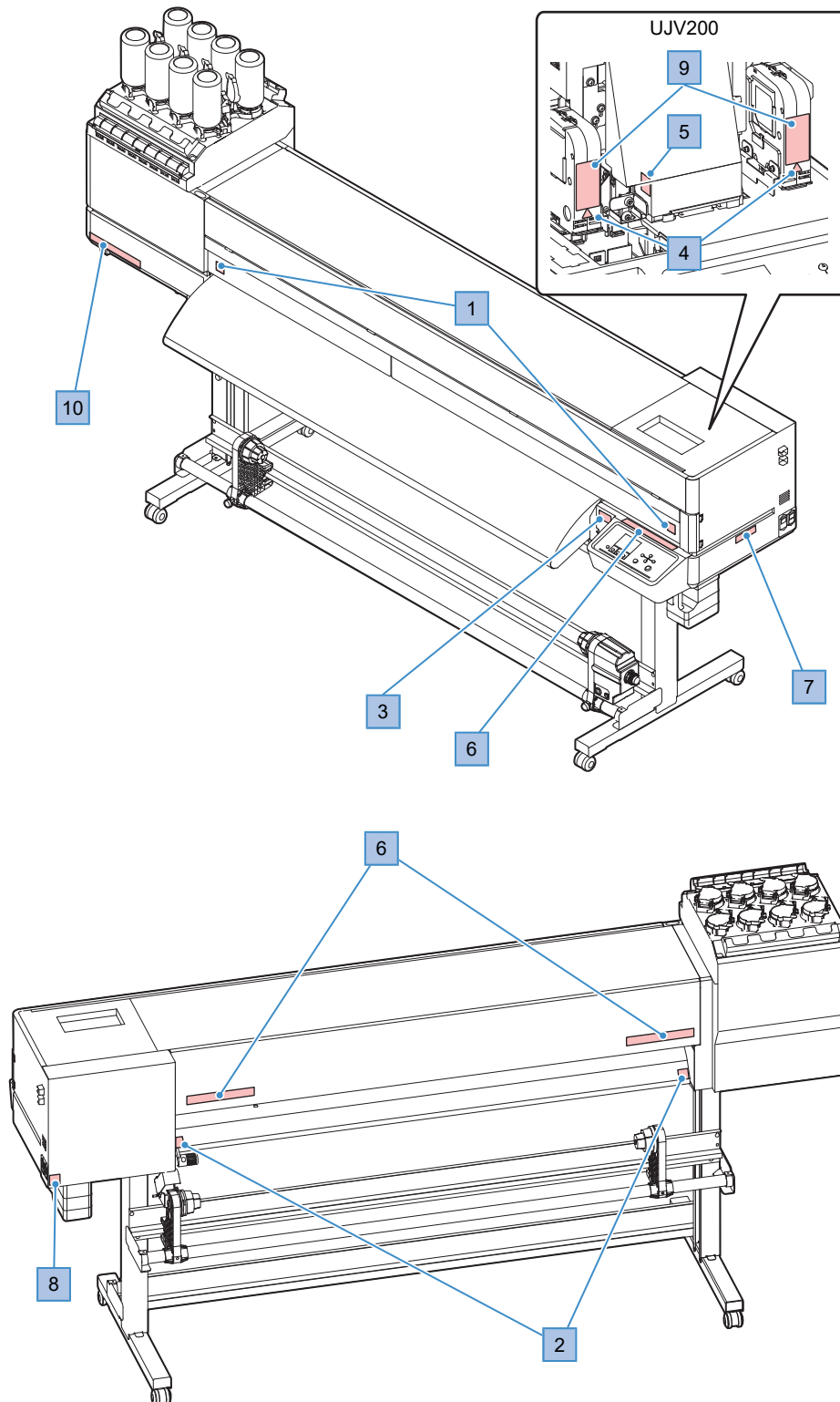



Warning Label

Make sure you fully understand the details indicated on the various warning labels.

If any of the warning labels becomes dirty and illegible or peel off, contact your local dealer or our service office to request new warning labels.



No.	Order code	Label	Details			
1	M907833		Indicates dangerous moving parts. Be careful not to put your hand in while the power is on, as you may hit the moving parts and injure yourself.			
2	M903239		Indicates hot parts. Do not touch the heater while it is energized as it may cause burns. • Preheater			
3	M903330		Wear safety glasses and gloves while working as ink may adhere to them.			
4	M919855		Indicates hot parts. Do not touch the heater while it is energized as it may cause burns. • Head unit (unit of measurement in decibel) • UV units (right, left)			
5	M903405		Be careful with the cutter as it may cause injury.			
6	M905811		Indicates dangerous moving parts. Touching it with the power on may cause injury.			
7	M916035	 <table border="1" data-bbox="549 1135 924 1267"> <tr> <td>This unit has two power cords. For removal of all power, disconnects both cords.</td> </tr> <tr> <td>Cet appareil a deux cordons secteur. Pour le mettre hors tension, débranchez ces deux cordons secteur.</td> </tr> <tr> <td>本機は、2本の電源ケーブルがある。電源をオフする場合、2本とも抜くこと。</td> </tr> </table>	This unit has two power cords. For removal of all power, disconnects both cords.	Cet appareil a deux cordons secteur. Pour le mettre hors tension, débranchez ces deux cordons secteur.	本機は、2本の電源ケーブルがある。電源をオフする場合、2本とも抜くこと。	Describes the power cable. Please observe the notes for your safety.
This unit has two power cords. For removal of all power, disconnects both cords.						
Cet appareil a deux cordons secteur. Pour le mettre hors tension, débranchez ces deux cordons secteur.						
本機は、2本の電源ケーブルがある。電源をオフする場合、2本とも抜くこと。						
8	M907935		Indicates dangerous live parts. Do not touch the product while it is energized to avoid risk of electric shock.			
9	M920199		Beware of ultraviolet light. Note that there is a UV irradiation device inside the equipment.			

No.	Order code	Label	Details
10	PA001-S		When opening the cover, be careful not to be directly under the cover. Disregarding this precaution may cause the machine to slide and result in injury.

Chapter 1 Before Use



This chapter

This chapter describes information essential before use, such as part names.

Part Names and Functions	24	Connecting a PC to the Product.....	35
Front.....	24	Using a LAN Cable	35
Rear and Right Side View.....	25	Using a USB Cable	36
Carriage	26	System Configuration	37
Station.....	26	Installing the Mimaki Driver.....	38
Platen.....	26	Installing RIP Software.....	38
Pinch Rollers and Grit Rollers.....	27	Obtaining Color Profiles	38
Media Sensor	27	Setting Up RIP Software	38
Power Supply Switch	28	Ink Replacement Method	40
Operating Panel	29	Messages informing the user of the ink levels40
Connecting the Power Cable.....	32	Replacing Ink	41
Turning On the Power	32		
Turning Off the Power	33		

1.1 Part Names and Functions

Front

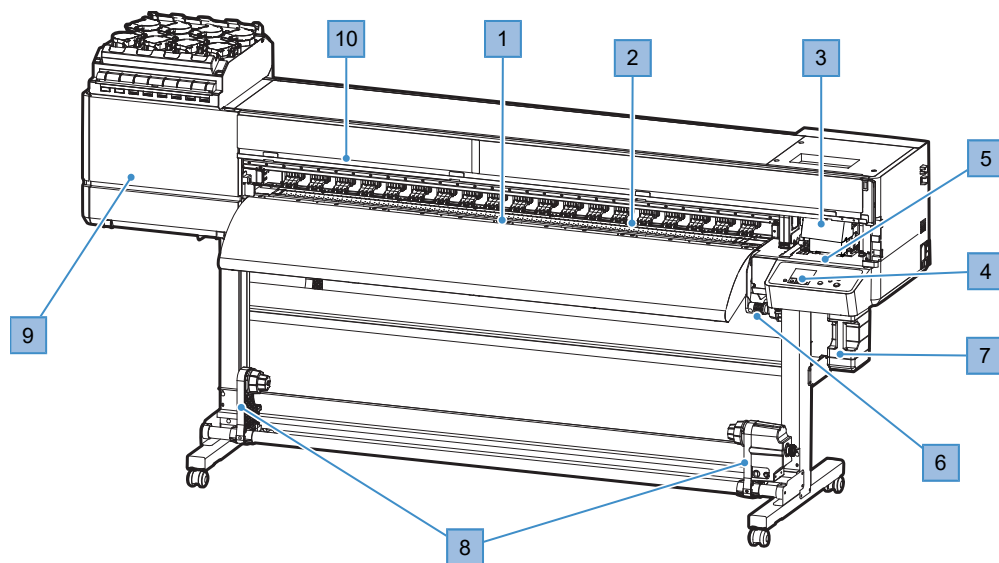

The opening/closing cover is open

No.	Name	Overview
1	Platen	Print area. "Platen"(P. 26)
2	Pinch roller Grit roller	The pinch rollers and grit rollers are used to grip and feed the media. "Pinch Rollers and Grit Rollers"(P. 27)
3	Carriage	Consists of a print head, the jam sensor, and the media cutter. "Carriage"(P. 26)
4	Operating Panel	Includes operating keys and displays indicating various settings and other items. "Operating Panel"(P. 29)
5	Station	Includes caps for protecting the print head, wipers, and an NCU (option) for monitoring print head nozzle conditions. "Station"(P. 26)
6	Clamp lever	Lowering the clamp lever secures the media. Raising the clamp lever releases the media. Linked to the clamp lever at the rear.
7	Waste Ink Tank	Contains the container for waste ink. "Waste Ink Tank Replacement"(P. 115)
8	Take-up unit	Rolls up the printed roll media. "Take-up unit"(P. 53)
9	Maintenance cover	Open the cover to perform maintenance on locations such as the carriage underside. Keep the cover closed, except during maintenance.
10	Opening/closing cover	Open the cover for loading the media, performing maintenance on the area around the platen, and for replacing consumable items. Printing and automatic maintenance are not possible while the covers are open.

Rear and Right Side View

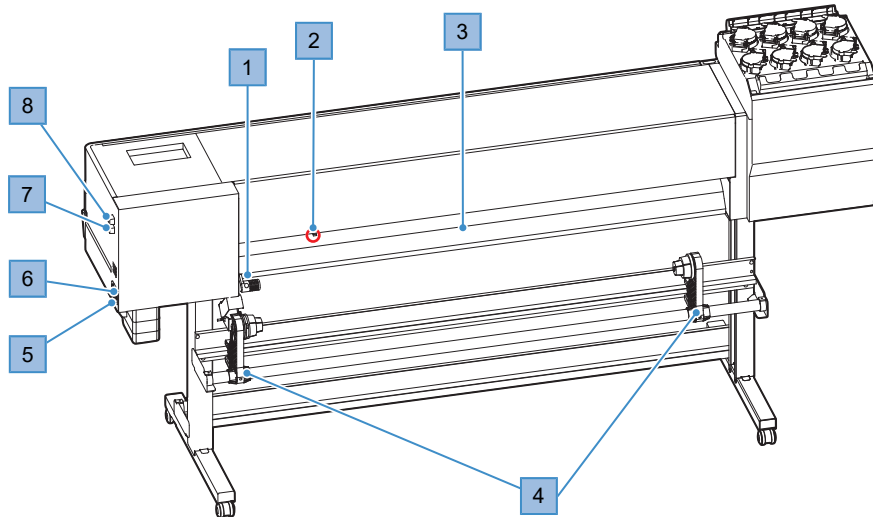

No.	Name	Overview
1	Clamp lever	Linked to the clamp lever at the front.
2	Media Sensor	Detects whether media is present. 📖 "Media Sensor"(P. 27)
3	Preheater	Preheats the media before printing to suppress rapid temperature change. Adjust the temperature setting to suit the type of media used. 📖 "Setting the Heater Temperature"(P. 64)
4	Feeding unit	Compatible with 2-inch and 3-inch paper cores. 📖 "Loading the Roll Media"(P. 57)
5	AC inlet	The inlet at the rear (INLET1) is for the machine and the inlet at the front (INLET2) is for the heater. Use the power cable provided. 📖 "Connecting the Power Cable"(P. 32)
6	Main power switch	The main power supply for the machine. To prevent ejection failures attributable to the print head (e.g., nozzle clogging or deflection), do not turn off the main power supply. 📖 "Power Supply Switch"(P. 28) 📖 "Turning On the Power"(P. 32) 📖 "Turning Off the Power"(P. 33)
7	LAN port	Connects to PC via a LAN cable. 📖 "Using a LAN Cable"(P. 35)
8	USB port	Connects to PC via a USB interface cable. 📖 "Using a USB Cable"(P. 36)

Carriage

The carriage includes a print head for ejecting ink, and a jam sensor for stopping the carriage when media clogs. Printing occurs as ink is ejected while traversing left and right.

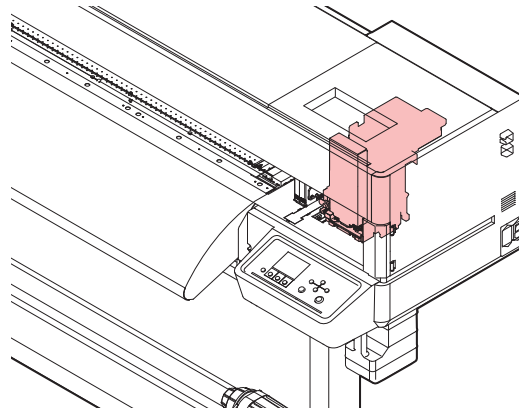

Station

The station includes caps for keeping the print head nozzle surface from drying out, a wiper required for print head maintenance, and an NCU (option) for monitoring print head nozzle conditions.

The NCU (Nozzle Check Unit) automatically checks whether the nozzle is clogged. Setting various functions enables automatic print head cleaning or printing using other nozzles. (NCU is optional.)

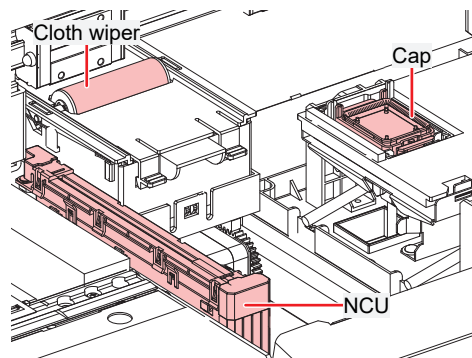

Platen

Print area. The platen secures the media under vacuum pressure. This also features a cutting slot for cutting the media.

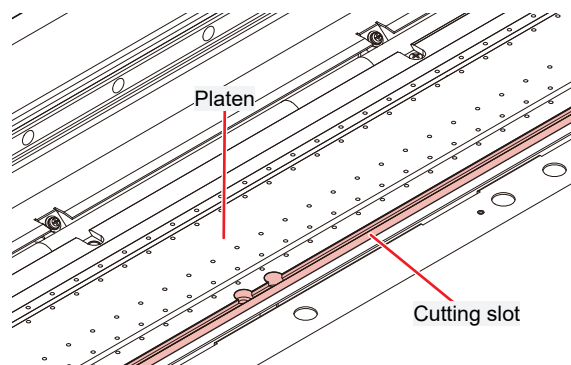

Pinch Rollers and Grit Rollers

The pinch rollers and grit rollers are used to grip and feed the media.

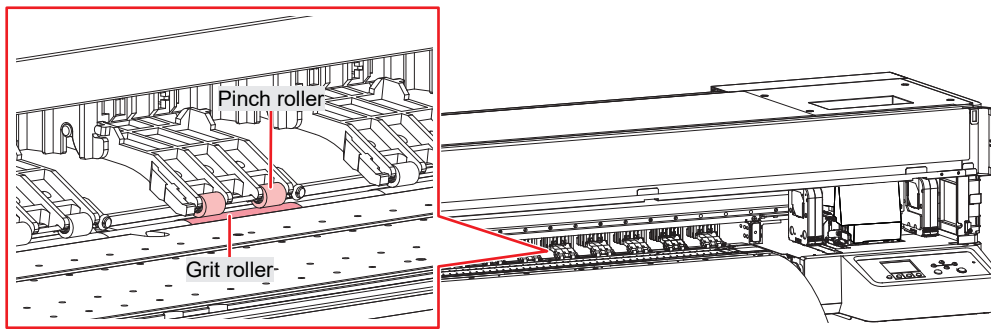

When the machine is not in use, raise the clamp lever to separate the pinch rollers from the grit rollers.

- Leaving the pinch rollers lowered may cause them to become deformed and prevent media from being fed correctly.
- Leaving media loaded will subject it to force from the pinch rollers, which may leave pinch roller marks on it.

Media Sensor

The media sensor detects the presence/absence of media. The sensor must be covered by the media to detect the media width.

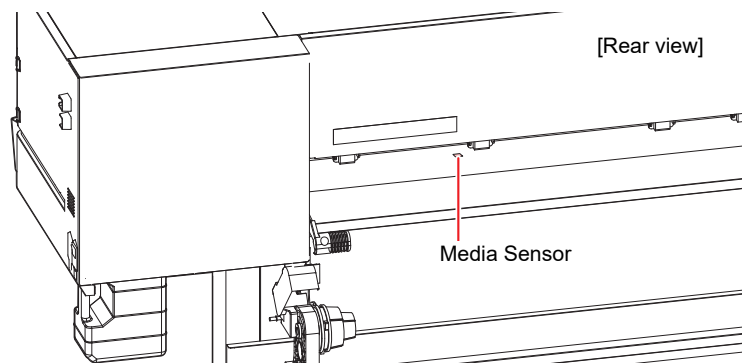

Power Supply Switch

● Main power switch

This is located at the rear on the right-hand side of the product.

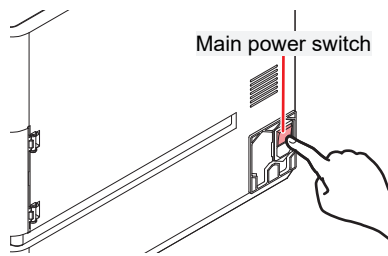

- Do not turn off the main power supply. Turning off the main power supply will disable the automatic maintenance function (including nozzle clogging prevention function and ink discharge channel cleaning function). This increases the risk of ejection failures (such as nozzle clogging or deflection).

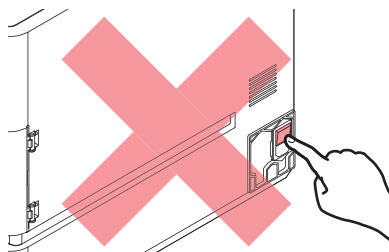

● [END/POWER] key





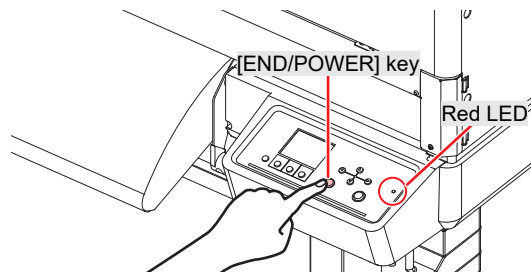



The [END/POWER] key is the key normally used to turn the power on and off.

To turn off the power, hold down the [END/POWER] key. Press the [ENTER] key once the instructions appear on the display.



Operating Panel

This is used to control the product and make/change settings.

No.	Name	Overview		
1	Display	 "Display"(P. 30)		
2	[SEL] key	Selects the function for the corresponding [FUNCTION] key.		
3	[FUNCTION] key	Used for test printing, head cleaning, and editing settings.  "[FUNCTION] key"(P. 31)		
4	[JOG] key 	Used to move the carriage, feed media, and select settings		
5	[END/POWER] key	Used to cancel the last setting entered, return to the previous level of the setting menu, or to turn power on and off <ul style="list-style-type: none"> • Illuminates in blue when the power is on.  "Turning On the Power"(P. 32) • To turn off the power, hold down the key.  "Turning Off the Power"(P. 33) 		
6	[ENTER] key	Used to move to the next level menu and to confirm settings. This can also be used to display product information.  "Displaying Machine Information (Local Guidance)"(P. 31)		
7	Status lamp	This lamp indicates the machine status.		
		Off	Indicates LOCAL mode. Used for test printing, maintenance, and settings	
		Light blue	Illuminated	Indicates REMOTE mode. The product is in standby to receive print data.
			Flashing	Indicates that printing is in progress. This also flashes to indicate test printing—for example, when printing built-in patterns.
		Blue	Illuminated	Indicates that data remains to be printed. Switch to REMOTE mode and start printing
		Green	Flashing	Indicates that automatic maintenance is underway. Some functions will be limited until maintenance has ended.
		Yellow	Flashing	Ink Near End status (very little ink remains).  "When Ink Near End is Displayed"(P. 40)
		Red	Flashing	An error has occurred. Refer to the error code list and take appropriate action.  "Error Message"(P. 131)
Illuminated	A system error (SYSTEM HALT) has occurred. Contact our service office.  "SYSTEM HALT"(P. 138)			
8	LED	To turn on power, press the [END/POWER] key until the red LED illuminates, then release the key.		

Display

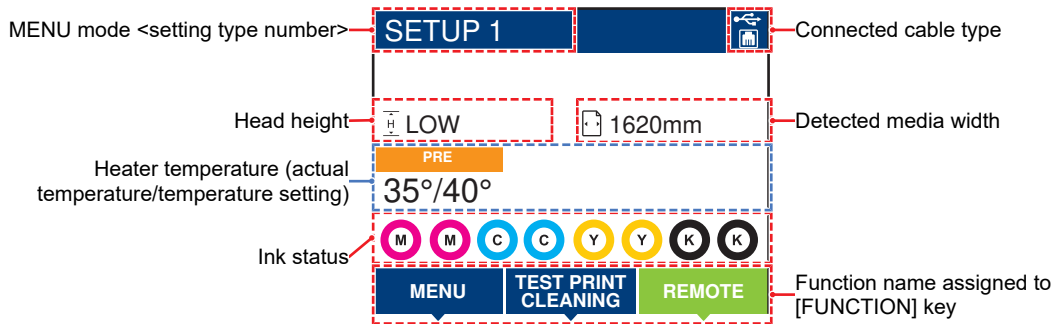

● Heater temperature

The heater status is indicated by different colors.

- Orange: Adjusting to temperature setting.
- Green: At temperature setting.
- Gray: Heater is turned off.

MENU mode

Four menu modes are available.

Name	Overview
LOCAL mode	Used for test printing, maintenance, and settings
REMOTE mode	Prints the print data received from a PC.
MENU mode	Press the [MENU] on the LOCAL mode screen to switch to MENU mode. This is used to set various functions.
NOT-READY mode	Status before media is detected















Ink status

The ink pack status such as remaining ink levels and ink errors are indicated by icons.

Icon	Overview
	Displays remaining ink levels using a 9-stage icon.
	Full
	1/8 used
	1/4 used
	3/8 used
	1/2 used
	5/8 used
	3/4 used
	7/8 used
	Very little ink remains. Prepare fresh ink.
	Printing is not possible. Displayed when ink is depleted or an ink error has occurred. "Ink error"(P. 130)

[FUNCTION] key

This section describes the functions and roles assigned to the [FUNCTION] key.

Icon	Overview
	Displays the various menu screens.  "Setup"(P. 79)
	Displays maintenance functions such as test printing and cleaning.
	Switches from LOCAL mode to REMOTE mode.
	Displays adjustment functions such as feed adjustment and drop position adjustment.
	Displays the Heater Temperature Setup screen.
	Clears received data.
	Used to switch from REMOTE mode to LOCAL mode
	Used to cut media
	Used to move to the previous menu screen
	Used to move to the next menu screen
	Used to close the confirmation screen in response to prompts or other messages
	Used to disable functions
	Indicates that the function is assigned. Displays settings and functions.
	Used to enable or disable multiple items

Displaying Machine Information (Local Guidance)

Press the [ENTER] key on the LOCAL mode screen to display the following information.

- Ink information: Displays ink type, remaining ink levels, and ink errors.
- Information: Displays information such as media width, head height, product serial number, firmware version, command version, and LAN connection status.
- Nozzle check: Displays the number of nozzles detected as clogged in the nozzle check.

1.2 Connecting the Power Cable

- 1** Check to confirm that the main power supply is turned off.
- 2** Connect the cable band to the machine.
- 3** Connect the power cable to the inlet of the machine.
- 4** Secure the power cable to the cable band.
 - Pass the power cable through the clamp and clamp until it clicks into place.

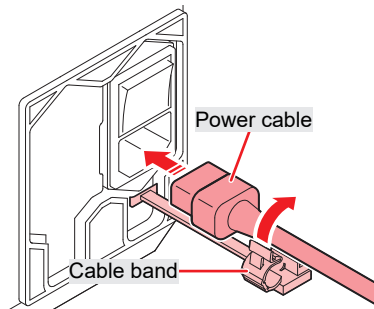

- 5** Plug the power plug into the power outlet.

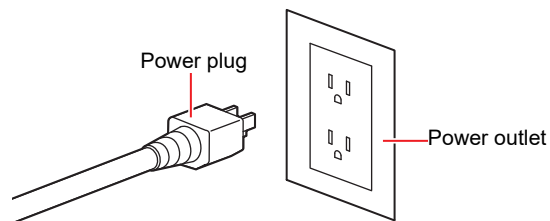

- Do not handle the power plug with wet hands. Disregarding this precaution may result in electric shock.

Turning On the Power

- 1** Check to confirm that the main power supply is turned on.
 - If the main power supply switch is not turned on, set to "I".

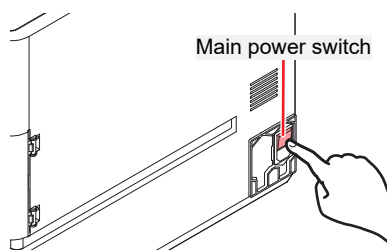

2 Hold down the [END/POWER] key to turn on power. (Press the key until the red LED on the upper right side illuminates.)

- The firmware version appears on the display, and the initial operation is executed. The machine will then enter the Media Select mode, and is ready for use.

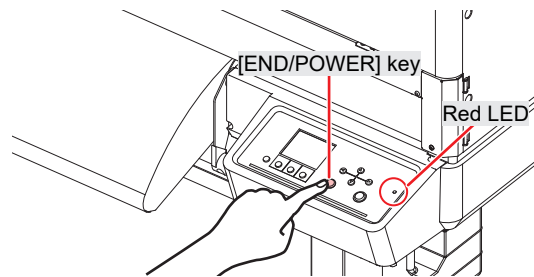

3 Turn on the power for the connected PC.



- Close the front cover and maintenance covers. Leaving any of the covers open will disable the automatic maintenance function (including nozzle clogging prevention function and waste ink draining channel cleaning function). This will increase the risk of failure or ejection failures (e.g., nozzle clogging or deflection).

Turning Off the Power



- Check the following when turning off power:
 - (1) The front cover and maintenance covers are closed.
 - Leaving any of the covers open will disable the automatic maintenance function (including nozzle clogging prevention function and waste ink draining channel cleaning function).
 - (2) The carriage has returned to the capping station.
 - If not, the print head nozzle may dry out, resulting in ejection failures (such as nozzle clogging or deflection).
 - (3) Data is not being received
 - (4) No errors have occurred.
 - ["Problems Causing Messages to Appear"\(P. 127\)](#)

1 Turn off the power to the PC connected.

2 Hold down the [END/ POWER] key.

- A power off confirmation screen appears. Press the [ENTER] key to turn the power off.

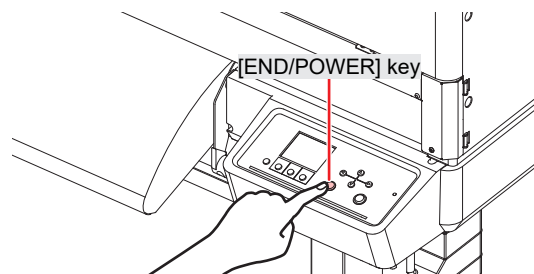



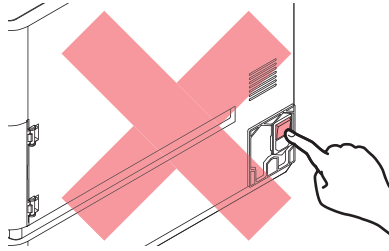

- Do not turn off the main power supply. Turning off the main power supply will disable the automatic maintenance function (including nozzle clogging prevention function and ink discharge channel cleaning function). This increases the risk of ejection failures (such as nozzle clogging or deflection).



1.3 Connecting a PC to the Product

Connect the machine to the RIP PC. The following cables can be used:

1.  ["Using a LAN Cable"\(P. 35\) \(Recommended\)](#)
2.  ["Using a USB Cable"\(P. 36\)](#)

Important! When using the USB cable

- Data may be transferred to the machine too slowly, **causing the carriage to pause at the left-hand or right-hand end** during printing.

Using a LAN Cable

Connect a PC to this product using a LAN cable. Insert a LAN cable until it engages with a click.



- Do not unplug the cable while data is being transferred.

● Network Connection Precautions

Make sure the network is set up as follows: Printing is not possible if the network is not set up correctly.

- Use a Category 6 or 6A LAN cable.
- The PC used to transfer print data must be located on the same network as this product. This product cannot be connected via a router.
- Use a 1000BASE-T compatible computer or switching hub. Printing requires 1000BASE-T support.

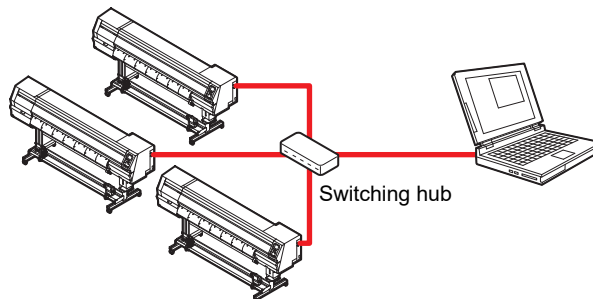

● Checking the LAN connection

1 Check the display on this product.

- Local guidance can be used for checking.  ["Displaying Machine Information \(Local Guidance\)"\(P. 31\)](#) Printing is not possible if "100Mbps", "10Mbps", or "No Connect" is displayed.

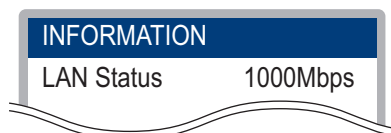

2 Check the lamp on the LAN connector.

- The LAN connector lamp illuminates when the machine is running.

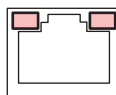

Color	Status	Overview
Green	Illuminated	Connected via 1000BASE-T
	Off	Connected via a network other than 1000BASE-T <ul style="list-style-type: none"> 1,000 Mbps is not supported if only the orange lamp is illuminated or flashing. Check the specifications for the PC, peripheral devices, and cable.
Orange	Illuminated	Linked up (connected).
	Flashing	Data being received
	Off	Link down (not connected)

Using a USB Cable

Connect a PC to this product using a USB interface cable.



- Do not unplug the cable while data is being transferred.



- Use RIP software that supports the USB interface.



- If the computer has no USB port, contact your local dealer or our service office.



When using the USB cable

- Data may be transferred to the machine too slowly, **causing the carriage to pause at the left-hand or right-hand end** during printing.

● USB Connection Precautions

- When connecting more than one UJV200 to one PC
 - If the PC has more than one USB port, try connecting to a different USB port to check whether the product is correctly recognized. If the product is still unrecognized even when connected to a different USB port, use a commercially-available USB active repeater cable.
- When extending the USB cable
 - Use a commercially-available USB active repeater cable. However, make sure that the combined length of the USB cable and the USB active repeater cable does not exceed 20 m.
 - If the USB cable is extended, this may reduce the data transfer speed to the machine, causing the carriage to pause at the left-hand or right-hand end during printing.
- USB high-speed mode peripheral devices
 - It may not be possible to recognize USB peripheral devices if USB high-speed mode peripheral devices (e.g., USB memory, USB HDD devices) are connected to the PC to which the product is connected. If external USB hard disk drives or other similar devices are connected, this may reduce the data transfer speed to the machine, causing the carriage to pause at the left-hand or right-hand end during printing.
- Unplugging USB memory devices
 - When unplugging USB memory devices from the PC to which this product is connected, use "Stop" in "Safely removing hardware" before unplugging. Otherwise, an [ERROR 201 Command Error] will occur.

1.4 System Configuration

Use RIP software to request to print data created using applications like Illustrator or Photoshop.

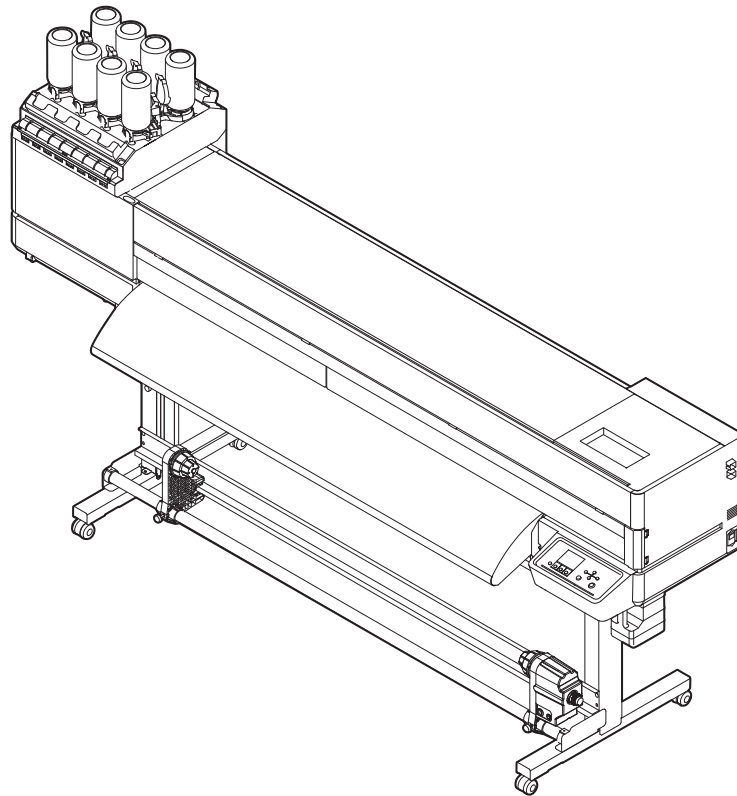
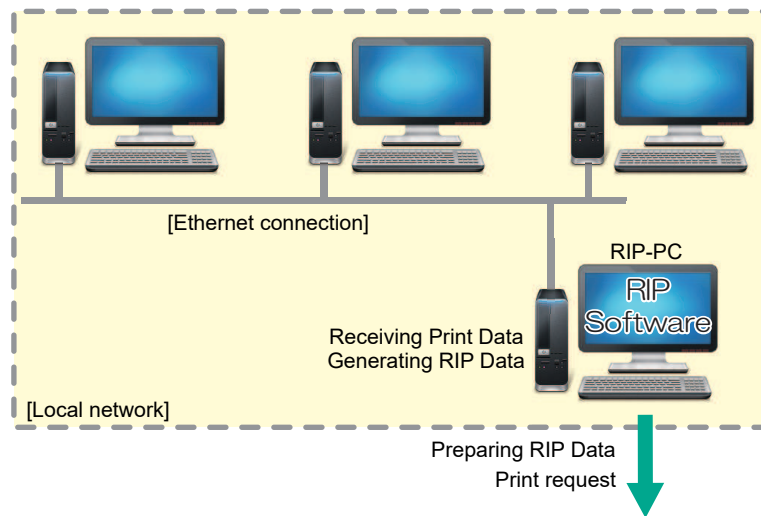

Installing the Mimaki Driver

1 Download the Mimaki driver from our website.

- <https://mimaki.com/download/inkjet.html>
[(Example: UJV200-160)] > [Driver/Utility]

2 Install the MIMAKI driver.

Installing RIP Software

The explanation here applies to MIMAKI RIP software (RasterLink).

1 Install RasterLink.

- The following icon appears on the PC desktop once the software has been installed.



- For more information, refer to the RasterLink installation guide. <https://mimaki.com/download/software.html>



- Once installed, activate the license for Rasterlink. Otherwise, "Profile Update" will not start.

Obtaining Color Profiles

Print quality (e.g., tone, bleeding) will vary depending on the media and ink set. To maintain consistent print quality, select a color profile that suits the media and ink set.

- The RasterLink Series includes a function allowing color profiles to be downloaded and installed directly from the Internet. For more information, refer to "Installing Profiles" in the RasterLink Series installation guide.
<https://mimaki.com/download/software.html>
[RasterLink Series used] > [Manuals]
- Color profiles for Mimaki RIP software (RasterLink) are available on the Mimaki website.
<https://mimaki.com/download/inkjet.html>
[(Example: UJV200-160)] > [Profile]

Setting Up RIP Software

The explanation here applies to MIMAKI RIP software (RasterLink).

1 Launch RasterLink.

- The [Printer Management] screen appears.
- To add a new model, launch RasterLink, then select [Environment] > [Printer Management].

2 Register the machine name (Example: UJV200-160).

(1) Click [Add].

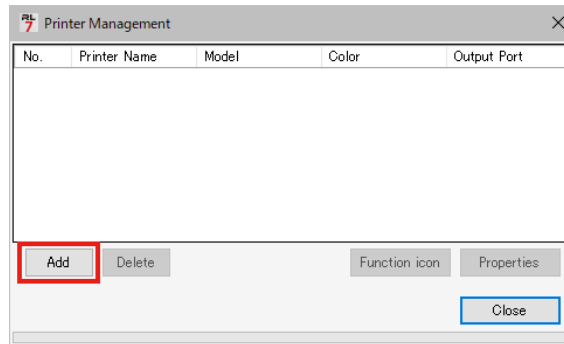

(2) Set the specifics for the machine.

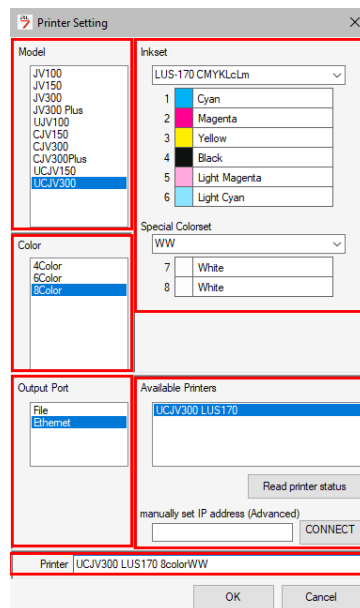

- Model: Select the model.
 - Color: Select the ink set filled.
 - Output Port: Select the cable connected.
 - Available Printers: Select UJV200-160 connected.
 - Printer: Enter a name as required.
- (3) Click [OK].
- A confirmation screen appears.
- (4) Click [Yes].
- Printer registration starts.



- For more information, refer to the RasterLink installation guide. <https://mimaki.com/download/software.html>

1.5 Ink Replacement Method

Messages informing the user of the ink levels

When Ink Near End is Displayed

Ink levels are low. We recommend replacing with new ink bottles as soon as possible, because the ink bottles are nearly empty. Printing is still possible but continuous printing and rewind printing may be interrupted, and some maintenance functions, such as cleaning, will be disabled. Note that ink may run out during printing.

To check which color ink needs to be replaced, press the [ENTER] key on the LOCAL mode screen.

 ["Displaying Machine Information \(Local Guidance\)"\(P. 31\)](#)

When Ink End is Displayed

The ink has run out. Replace with a new ink bottle.

Read the following thoroughly and make sure you understand its contents before replacing an ink bottle.

 ["Notes on Handling Ink or any Other Liquid Used with the Machine"\(P. 12\)](#)



- Pay close attention to ventilation and be sure to wear safety glasses, gloves, and a mask when handling ink, maintenance liquid, waste ink, or other solutions used with the machine. Leaking ink may adhere to the skin or get into the eyes or mouth.

Replacing Ink

● Remove the Ink bottle

- 1 Rotate the lever on the tank section from left to right.

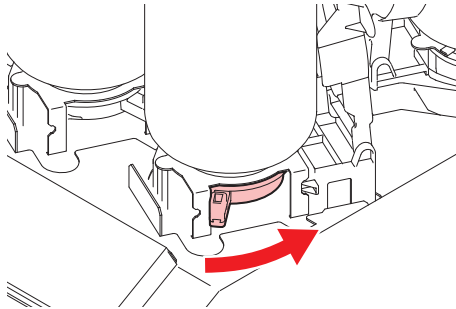

- Never attempt to rotate the ink bottles. Doing so may result in leaking ink.

- 2 Lift the ink bottles vertically.

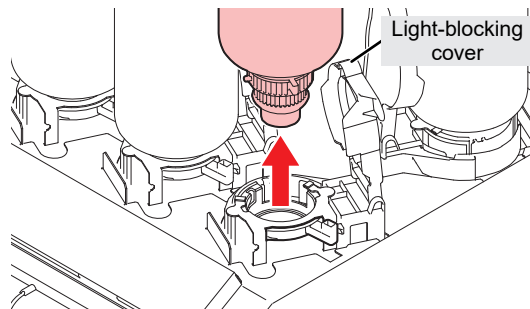

- Check to confirm that the light-blocking cover is closed when removing ink bottles. Close the light-blocking cover by hand if it is open. If the light-blocking cover is left open, the ink may harden, resulting in printer failure.
- Be careful to prevent ink leaks from the ink bottles.



- The O-rings fitted to the bottle caps may become detached when removing ink bottles. Refit the O-ring if it becomes detached.

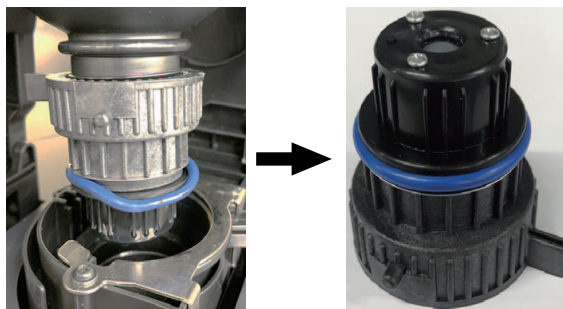

3 Soak up any ink droplets on the ink bottle caps.

- Use a wipe filter to absorb ink droplets to the extent that they do not drip.

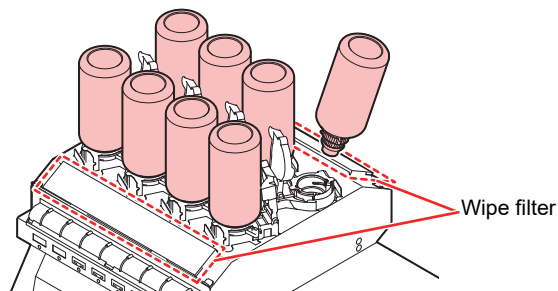

4 Wipe off any ink on the ink bottle caps with the recommended non-woven fabric.



- Check to confirm that there is no foreign matter, such as non-woven fabric scraps or dust, adhering to the ink bottle caps. Continuing to use it when it is dirty may result in foreign matter blocking the ink channels, causing ink leakage.

5 Remove the bottle caps from the ink bottles.

- If the ink bottle caps are tight, remove using a tightening tool.

6 Remove the ink IC chip.

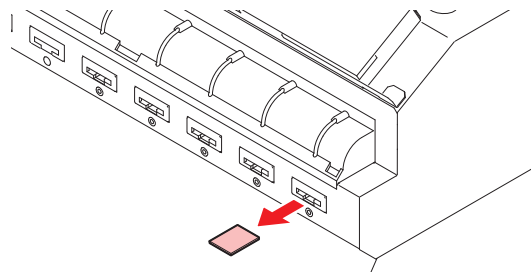

- When disposing of ink, maintenance liquid or other liquid used with the product, or containers or non-woven fabric contaminated with ink or other liquid, contact an industrial waste disposal operator or dispose of the product in accordance with the local laws and regulations.

● Prepare the Ink bottle

1 Shake the Ink bottle to the left and right slowly at least 20 times.

- Tighten the ink bottle lid securely, then shake the bottle slowly from left to right to ensure that the ink moves inside, holding the ink bottle lid with a piece of recommended non-woven fabric.

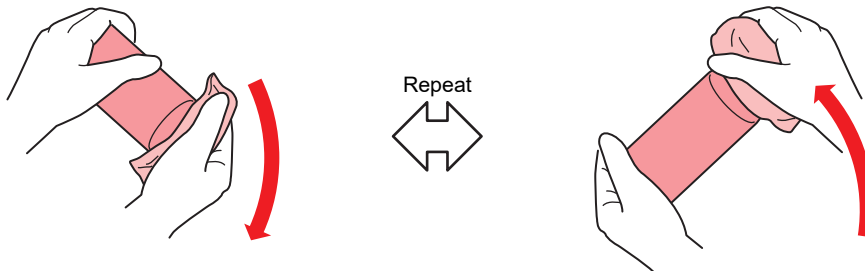

- Shake slowly. If the bottle is shaken too violently, ink may leak out or the air mixed in the ink may cause nozzle clogging.
- If the ink bottle is partially used, tilt it slowly until the ink bottle is upright.

2 Remove the ink bottle lid.

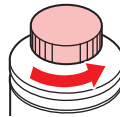

Important! If the mouth of the ink bottle is fitted with a seal

- Cut the seal open using a craft knife. There is a risk of ink leakage if parts of the seal remain.

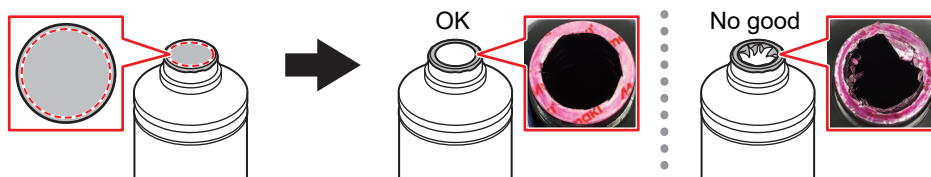

- Take care not to damage the mouth of the ink bottle. There is a risk of ink leakage if the mouth is damaged.
- Be careful not to drop any of the seal fragments into the ink bottle. If the ink bottle is used with seal fragments inside, these may clog the bottle cap, preventing ink from being supplied.

3 Attach the bottle cap to the ink bottle.

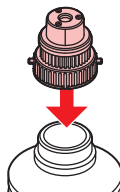



- Wipe off any ink or maintenance liquid remaining on the ink bottle or the bottle cap. Otherwise there is a risk of ink leakage due to loosening of the ink bottle cap.

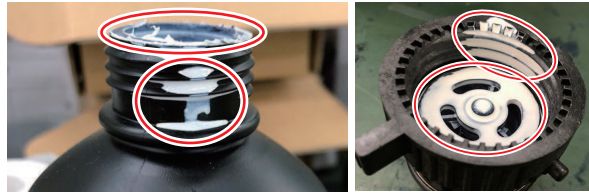

- Check to confirm that there is no foreign matter, such as paper towel scraps or dust, adhering to the ink bottle caps. If foreign matter is present, this may block the ink path and lead to leakage.

4 Use the tightening jig to tighten the ink bottle caps in place.

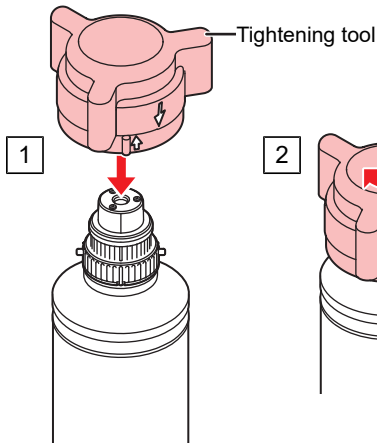

[SPA-0232]



Position the upper arrow within this range!

Good example



Bad example



[SPA-0328]



Position the upper arrow within this range!

Good example

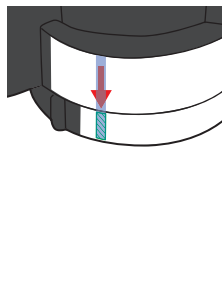

Bad example

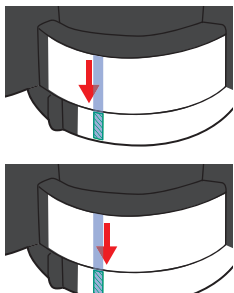

- Do not overtighten the ink bottle caps. Disregarding this precaution may result in damage, idling or ink leakage. If the arrow goes beyond the range indicated above, loosen the bottle cap, and repeat the steps again.
- Do not leave ink bottles with the ink bottle caps fitted for extended periods. Disregarding this precaution may result in the ink hardening.

5 Turn the ink bottle upside-down to check that no ink leaks occur.

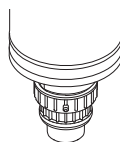

● Mount the Ink bottle

The order of Ink bottle to be set depends on the ink set you are currently using. Check the ink slot numbers and insert the correct color Ink bottle.

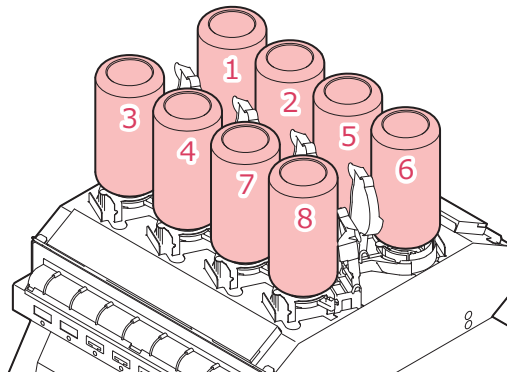

1 Mount the ink bottles.

- Rotate the lever from the left to the right end, then mount the ink bottle.

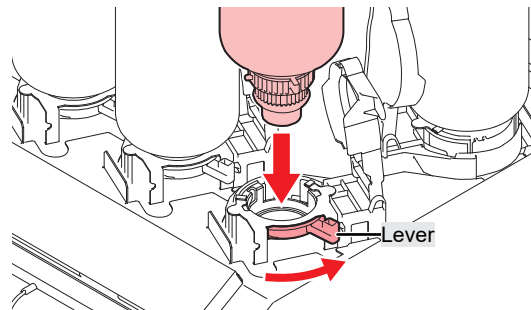

- You may apply the maintenance liquid onto the O-ring of the ink bottle caps so that the ink bottle can be inserted easily. Use the appropriate maintenance liquid to suit the ink being used.



2 Rotate the lever from right to left to secure the bottle in place.



- Never attempt to rotate the ink bottles. Doing so may result in leaking ink.



- Once the ink bottle is mounted, use up the ink as quickly as possible.



- After setting the ink bottle, it may take some time for a bottle replacement-related error to clear. If the error is not cleared after waiting approximately two minutes, please reinstall the ink bottle.

Chapter 2 Printing



This chapter

This chapter describes printing procedures and settings.

Print Process	48	Head Cleaning.....	67
Adjusting Print Head Height	51	Auto Correction	68
Loading the Media	52	Feed Correction.....	69
Media	52	Feed Correction Procedure.....	69
Take-up unit	53	Correcting the Drop Position	71
Feeding unit	55	Drop Position Correction Procedure	71
Loading the Roll Media	57	Preparing RIP data	73
Registering the Media	62	Printing	75
Setting the Heater Temperature	64	Changing the origin	75
Test Printing	65	Starting Printing	76
Changing the Layout Direction for Test		Stopping Printing (Data Clear)	77
Printing	65	Cutting the media	78
Checking White Ink Ejection	66		
Ejection Failures.....	66		

2.1 Print Process

1. Turn on the power.

 ["Turning On the Power"\(P. 32\)](#)

2. Connect a RIP PC to the machine.

 ["Using a USB Cable"\(P. 36\)](#)

 ["Using a LAN Cable"\(P. 35\)](#)

3. Setting Up RIP Software

 ["Installing RIP Software"\(P. 38\)](#) (required first time only)

 ["Obtaining Color Profiles"\(P. 38\)](#)

 ["Setting Up RIP Software"\(P. 38\)](#) (required first time only)

4. Adjusting Print Head Height

Adjust the height adjustment lever to suit the media.

 ["Adjusting Print Head Height"\(P. 51\)](#)

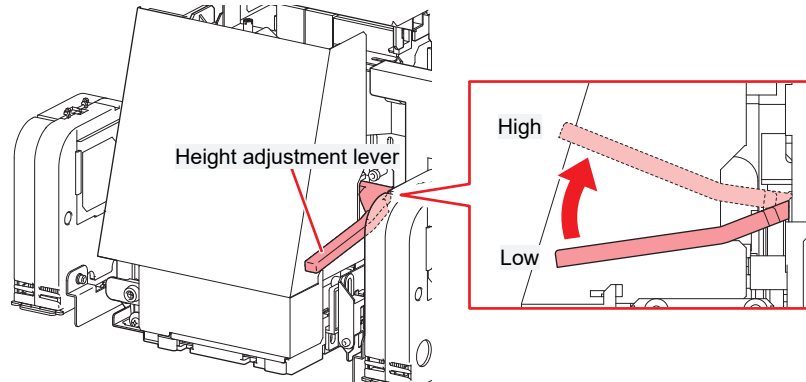

5. Loading the Media

This machine can be used with roll media and leaf media.  ["Loading the Media"\(P. 52\)](#)

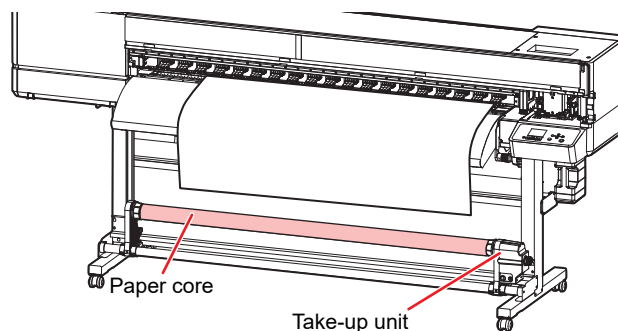

6. Setting the Heater Temperature

☞ "Setting the Heater Temperature"(P. 64)

7. Check the state of the print head nozzles.

☞ "Test Printing"(P. 65)

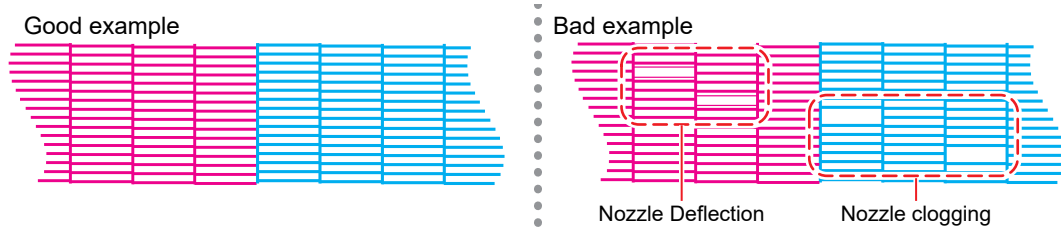

8. Clean the head to clear malfunctioning nozzles.

There are three different head cleaning methods. Choose the method based on test results.

☞ "Head Cleaning"(P. 67)

9. Adjust the media feed amount.

☞ "Feed Correction"(P. 69)

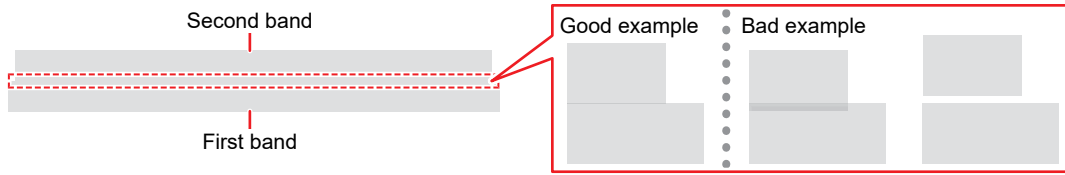

10. Adjust the drop position for bi-directional printing.

☞ "Correcting the Drop Position"(P. 71)

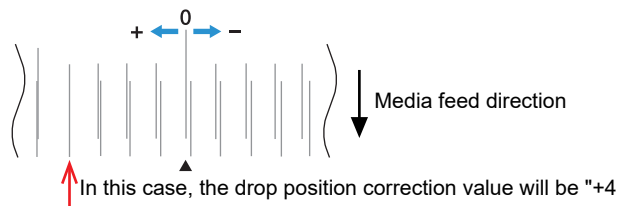

11. Preparing RIP data

☞ "Preparing RIP data"(P. 73)

12. Printing RIP data

☞ "Printing"(P. 75)

13. Cutting the media

☞ "Cutting the media"(P. 78)

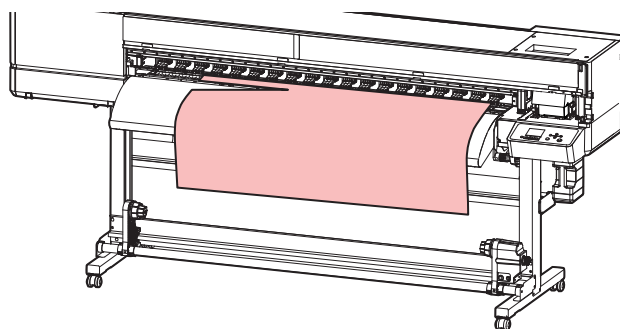

2.2 Adjusting Print Head Height

Adjust the height of the print head according to the thickness of the media you are using.

Range	Gap between print head and platen
Low (recommended)	1.5 mm (default setting)
High	2.0 mm



- Be sure to correct the dot position after altering the print head height.
 ["Correcting the Drop Position"\(P. 71\)](#)



- With inkjet printers, if the gap between the print head and media increases, the ink droplets tend to vaporize before they reach the media. Vaporized ink may adhere to the print head nozzle surface and media, affecting print quality and causing failure of the print head. Adjust the print head height to suit the media.

1 On the LOCAL mode screen, select [MENU] > [Maintenance], then press the [ENTER] key.

- The Maintenance menu is displayed.

2 Select [Station Maint.] > [Head height switching], then press the [ENTER] key.

- The carriage moves over the platen.

3 Use the height adjustment lever to adjust the height.

- Adjust the height adjustment lever so that it is at the desired height. If the lever is not set to the correct position, problems such as media jamming and misting may occur, resulting in impaired print quality.

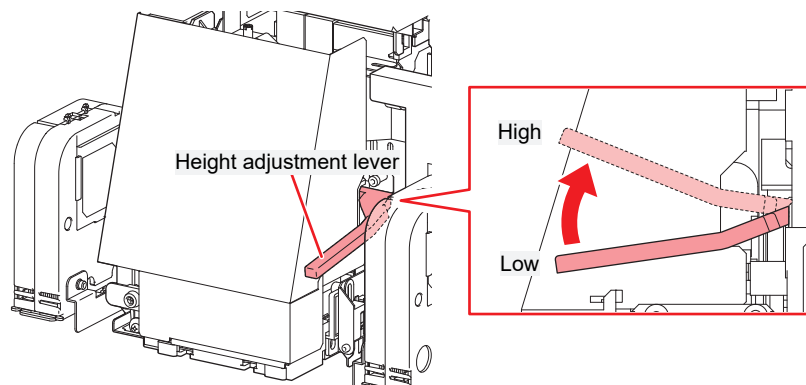

4 Press the [ENTER] key.

5 Select [LOW/HIGH] on the screen, then press the [ENTER] key.

2.3 Loading the Media



- Adjust the head height before loading media. Moving the carriage after the media has been loaded may result in the print head coming into contact with the media and being damaged.

Media

● Media handling precautions



- Use Mimaki-approved media to ensure consistent high-quality printing.

WARNING



- Assign at least two persons to load roll media. Disregarding this precaution may result in low back pain due to the weight of media.

NOTICE



- Protect media from dust when stored. Otherwise print quality may be reduced.
- When storing standard-size media rolled up, store with the coated surface facing out.



- Do not leave the media in the machine when not in use. Otherwise dust may accumulate on the media. Do not use media that has been wiped free of dust. Wiping media can generate static electricity, possibly affecting print quality.
- Do not use media immediately after removing it from the package. The media may expand or contract depending on the temperature and humidity of the location in which it was stored. Allow the media to stand for at least 30 minutes in the same indoor environment as the machine before loading it.
- Do not use media if it is curled. Curled media may not only damage the print head, but may also affect print quality.



- The underside of the media may be soiled depending on how the printed media has been stored (due to weight when laying printed media rolls horizontally, for example) and the media type. Perform a test beforehand to check that the media does not transfer ink to the underside of the adjacent media.

Take-up unit

Use the switch on the take-up unit to change the media take-up direction.

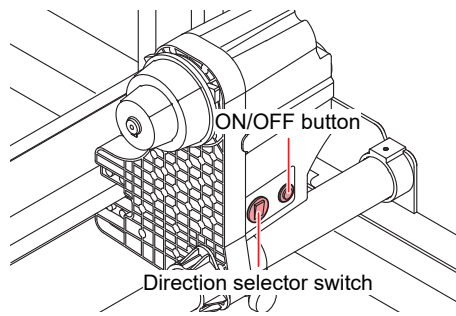

Name	Overview	
Direction selector switch	Up	To take up media with printed surface on the inside
	Down	To take up media with printed surface on the outside
ON/OFF button	Press the button to start/stop the take-up unit. The setting can be altered so that the take-up unit operates only while the button is depressed.  "Function Setting Menu"(P. 87)	

Adjusting the Torque Limiter

The left and right take-up units are fitted with a torque limiter.

Turn the torque limiter adjustment nut to adjust take-up tension. When adjusting the torque limiters, be sure to adjust to the same torque for both the left and right take-up units.

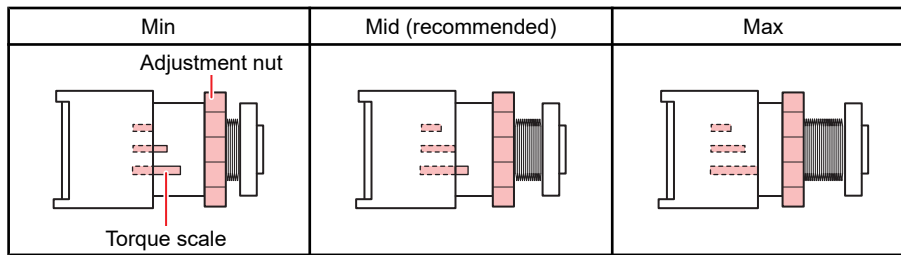

- For normal printing: Adjust the torque to "Mid".
- Depending on the media, increasing the torque may cause image defects due to the pinch roller and grit rollers failing to grip the media. Reduce the torque if the media slips.

● Increase tension (clockwise)

Increase tension when using with heavy or thick media, such as tarpaulin. Perform adjustments manually.

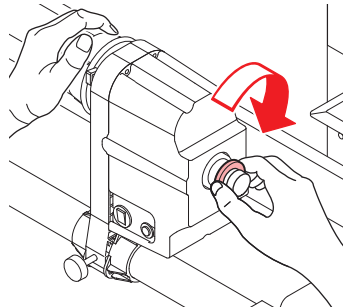

- Do not use the torque adjustment handle. Using the torque adjustment handle will cause overtightening. Overtightening may damage the take-up unit.

● Decrease tension (counterclockwise).

Decrease tension when using lightweight media. Use the "torque adjustment handle" provided.

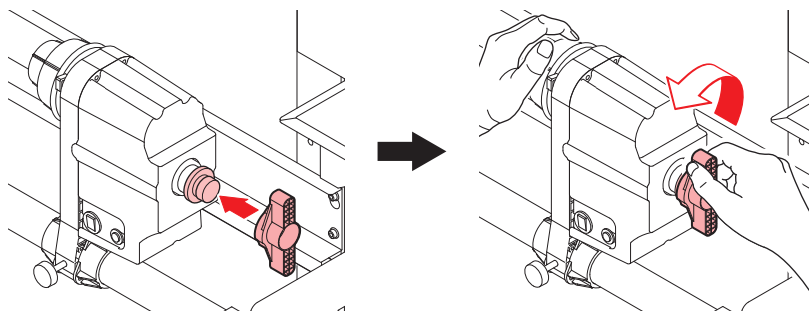

Feeding unit

Using the Media Stopper

When pulling out a fixed length of media by hand, the roll holder locks, stopping the media from being pulled out.

● Lock the media stopper

Push the side pin while pressing on the media stopper. Releasing the media stopper in this state locks the roll holder.

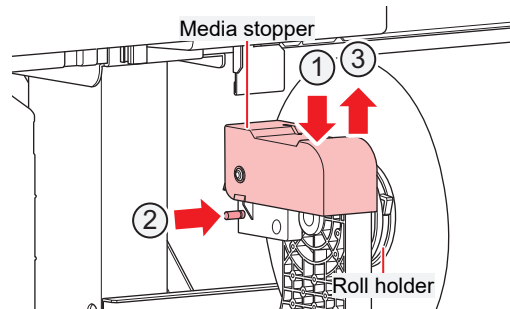

- Be sure to lock the media stopper when loading roll media or printing.

● Release the media stopper

Press the media stopper to release the roll holder.

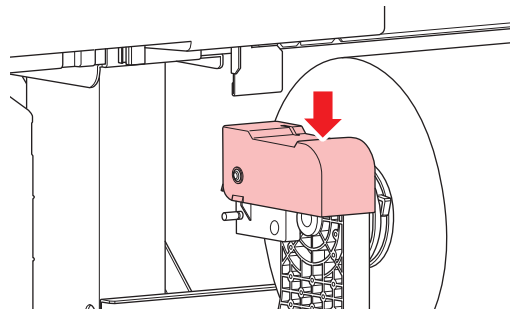

Roll Holder Setting Position

Loosen the knob screw on the rear left roll holder, then move it.

The leg stay has a label showing roll holder mounting positions. Use it as a reference to move the roll holder, then secure using the knob screw.

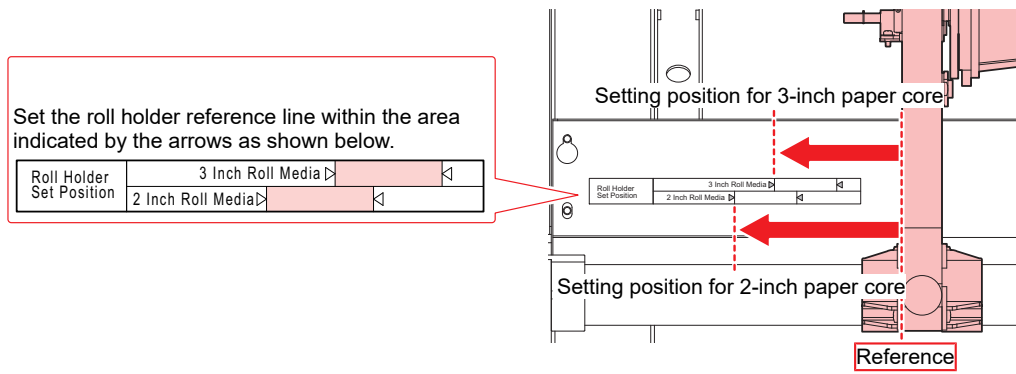

Loading the Roll Media

1 Raise the clamp lever.

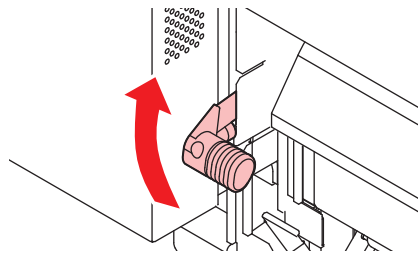

2 Move the rear left roll holder to the roll setting position.

- Unscrew the roll holder retaining screw, move the roll holder, then retighten the retaining screw.
 ["Roll Holder Setting Position"\(P. 56\)](#)

3 Insert the paper core of the roll media on to the rear left roll holder.

- Push in until the paper core moves no farther.

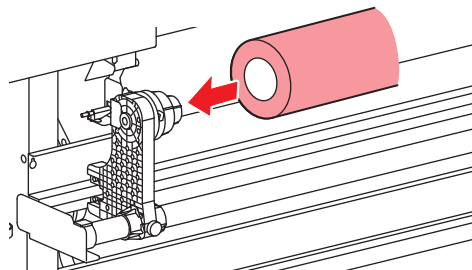

4 Insert the rear right roll holder into the paper core.

- Unscrew the roll holder retaining screw, move the roll holder, then retighten the retaining screw.

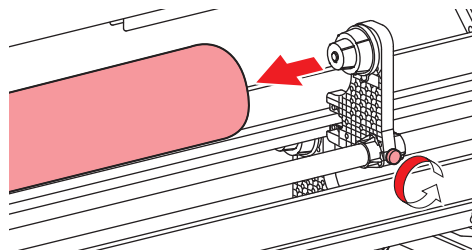

5 Insert the media between the pinch rollers and the grit rollers.



- Inserting the media at an angle allows smooth insertion without catching or sticking.

6 Lower the clamp lever.

- Hold the media with the pinch roller and grit rollers.

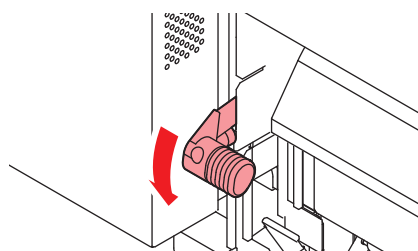

7 Lock the media stopper.

-  "Using the Media Stopper"(P. 55)

8 Move to the front of the machine, raise the clamp lever and pull out the media.

- Make sure the media does not fall to the rear.



- Adjust the rear roll holder position so that the media does not cover the right-hand slit line on the platen. Movement at an angle may result in damage to the print head.

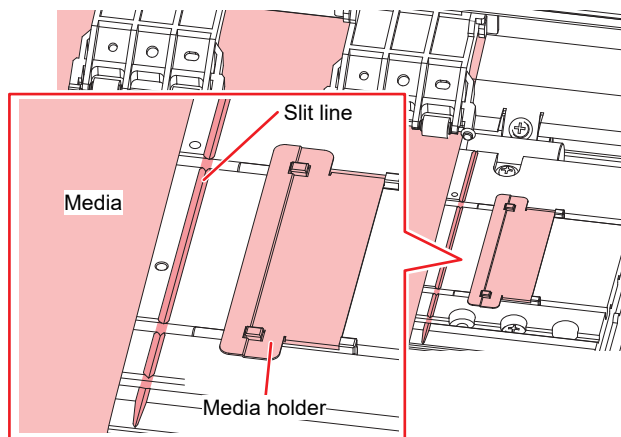

- The areas extending 5 mm from both sides of the media are margins.

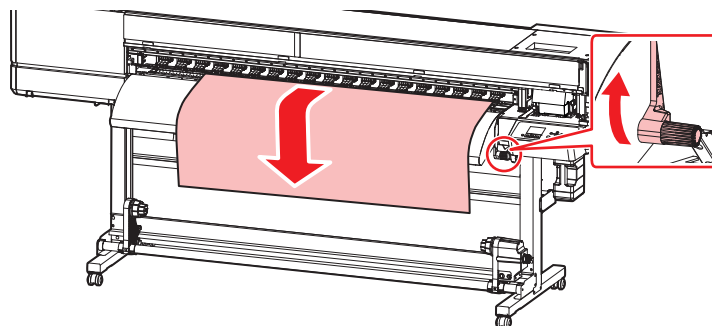
9 Raise the clamp lever.**10 Gently pull out the media and stop at the position where it is gently locked in place.****11 Check how far the media was pulled out.**

- Pull the front edge of the media gently at several points to confirm that the media was pulled out by the same amount.

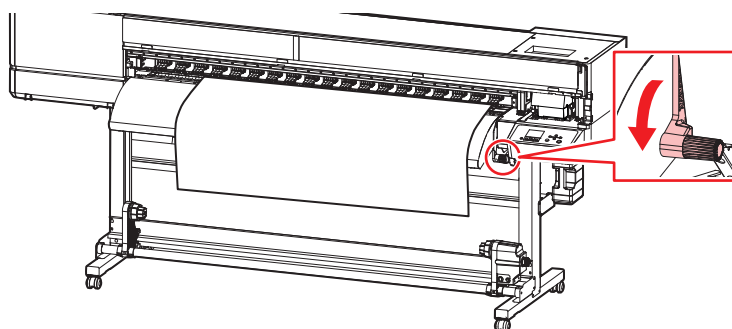
12 Lower the clamp lever.



- Do not pull the media when the clamp lever is lowered (the media is clamped). Doing so may damage the machine.

13 Secure the media in the media holder.

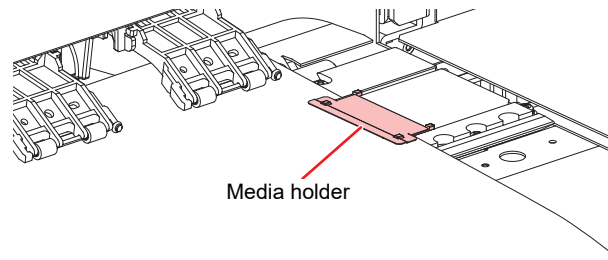

- Do not use the media holder when printing on thicker media. Use the media holder when detecting media.
- Do not perform media detection if there are printed materials or stains on the media on the platen. This will cause media detection to fail.

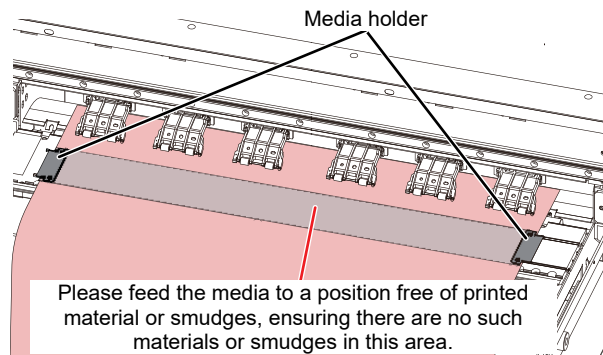

14 Select the media to be used.

Media selection	1/2
● PVC	1300 mm
○ Tarpaulin	1600 mm
○ Unregistered	
○ Unregistered	



- To use unregistered media, select [Unregistered] to register the media. ["Registering the Media"\(P. 62\)](#)

15 Detect the media width.

- No change: Only the right side of the media holder is detected.
- Media width re-detection: The media width is detected.

PVC	
Media Width	1300 mm
	No change Media width



- Media width may not be detected correctly for certain colors or types of media. When media width cannot be detected correctly, set the media width detection method to "MANUAL".
- If the media width detection method is set to "MANUAL", set the media width manually ([MENU] > [Media Setting] > [Media Information] > [Media Width] > [Detection Type] (P. 80)).
- A notification reading "Media Set Position R" will appear after media width detection if the media is too far to the right of the specified position. Reload media in the specified position.
- If Media Remain Manage is set to "ON", the Input Media Length screen will be displayed. ([MENU] > [Media Setting] > [Media Information] > [Media Remain] > [Media Remain Manage] (P. 80)).

16 Load an empty paper core on the take-up unit.

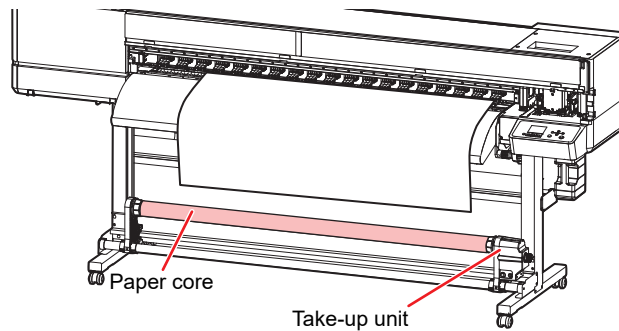

- Use the take-up unit for media with low stiffness (such as tarpaulin). If not, the media may rise up on the platen and damage a print head.

17 Press \blacktriangledown to feed the media until it reaches the paper core on the take-up unit, then press the [ENTER] key.

18 Secure the middle of the media to the paper core with adhesive tape, then secure the left and right sides of the media.

- Pull the lower edge of the media evenly on both the left and right sides, check to confirm that it is free of sagging and creasing, then affix the tape.

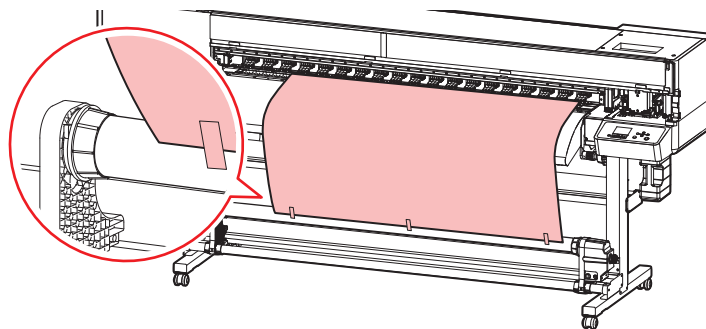

19 Press \blacktriangledown to wrap the media about one and a half turns around the paper core, then press the [ENTER] key.



- Move the take-up unit to the left or right when it is not in use. Print quality may be affected if the front edge of the media hits the take-up unit.

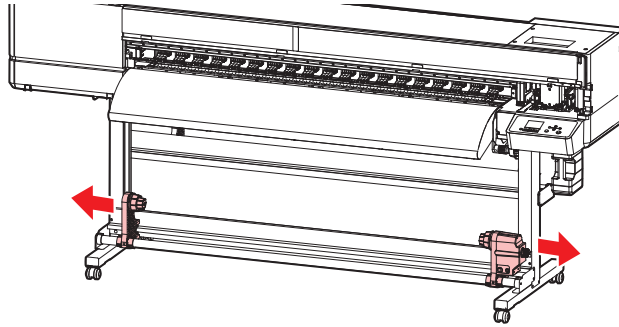

Registering the Media

When the clamp lever is lowered with media being loaded, the Select Use Media screen is displayed. Registration is required to use media that is not registered on the machine.

1 Select [Unregistered].

Media selection		1/2
<input checked="" type="radio"/>	PVC	1300 mm
<input type="radio"/>	Tarpaulin	1600 mm
<input type="radio"/>	Unregistered	
<input type="radio"/>	Unregistered	

2 Select the media type.

Media Type	
<input checked="" type="radio"/>	PVC
<input type="radio"/>	Tarpaulin
<input type="radio"/>	Transfer paper
<input type="radio"/>	Illuminated Film
<input type="radio"/>	Cutting Sheet

3 Select the media width detection type.

- AUTO: The media width is automatically detected.
- MANUAL: The media width is manually set.

Media Registration	
Media Detection Type	
Please Select.	
	AUTO
	MANUAL



- Media width may not be detected correctly for certain colors or types of media. When media width cannot be detected correctly, set the media width detection method to "MANUAL".

4 Select the method for managing the media remaining amount.

- Select whether or not to manage the media remaining amount with the machine.

Media Registration	
Media Remain Manage	
Please Select.	
	ON
	OFF

5 Enter the name to be displayed.

- If you do not register the name, press the [ENTER] key.

Media Name Change	
Media 3	
will be changed	
(maximum 10 characters)	

6 Select whether or not to register the set information.

do you optimize setting?	
	Execute
	Do not



- You can change the settings later.  ["Media Setting Menu"\(P. 80\)](#)
-

2.4 Setting the Heater Temperature



- Adjust the heater temperature to suit the media type and characteristics. Depending on the type, the media may expand or shrink or become rippled.



- The temperature setting in the RIP software takes precedence. If you are using the Mimaki RIP software (RasterLink), the recommended values are stored in the color profile.

Name	Overview
PRE (Preheater)	Preheats the media before printing to suppress rapid temperature change.

- 1 On the LOCAL mode screen, select [HEATER].**

 - The Heater Temperature Setup screen appears.
- 2 Enter the heater temperatures, then press the [ENTER] key.**

 - Printing is possible once the heater temperatures reach the temperature settings ± 3 °C.

2.5 Test Printing

Print a test pattern to confirm that the ink prints correctly. Perform head cleaning if you observe any ejection failures (e.g., nozzle clogging or deflection).

 ["Head Cleaning"\(P. 67\)](#)

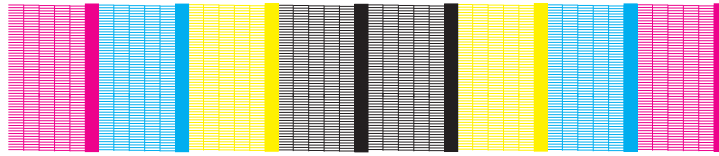

Check beforehand

- Was the print head adjusted?  ["Adjusting Print Head Height"\(P. 51\)](#)
- Is media loaded?  ["Loading the Media"\(P. 52\)](#)



- Load media at least 300 mm wide. You cannot print the entire pattern if media less than 300 mm wide is used.



- Select [Maintenance] > [Nozzle Recovery] > [Test Print], then select "ON" to perform nozzle recovery and test printing.
Registration is required to perform nozzle recovery.  ["Registering Nozzle Recovery Manually"\(P. 86\)](#)

Changing the Layout Direction for Test Printing

You can change the layout direction for test printing.

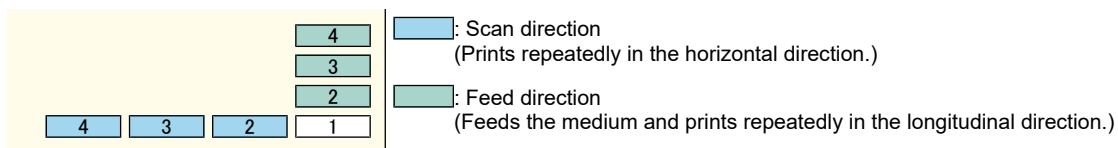

- 1** On the LOCAL mode screen, select [TEST PRINT/CLEANING] > [Test Print], then press the [ENTER] key.
 - The Test Print menu is displayed.
- 2** Select [Scan Dir.] or [Feed Dir.], then press the [ENTER] key.
 - Test printing starts.

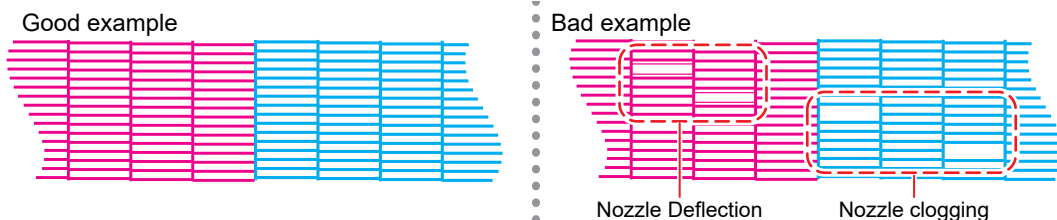

- 3** Check the print results.

Checking White Ink Ejection

The following two methods are available for checking white ink:

- Print on clear film.
- Print the background for the test pattern using black ink.

● Method for printing the background using black ink

1 On the LOCAL mode screen, select [TEST PRINT/CLEANING] > [Test Print], then press the [ENTER] key.

- The Test Print menu is displayed.

2 Select [SpotColor Check], then press the [ENTER] key.

- Test printing starts.
- The layout direction is fixed at [Scan direction].

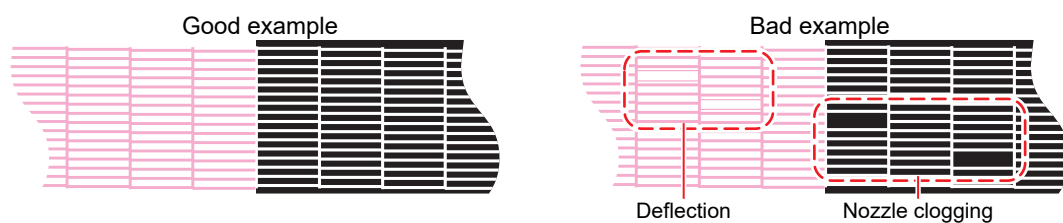

3 Check the print results.

Ejection Failures

Typical examples of ejection failures (e.g., nozzle clogging, deflection) are as shown below. In order to prevent printing in such a state, check whether the ink has been properly ejected regularly before printing.

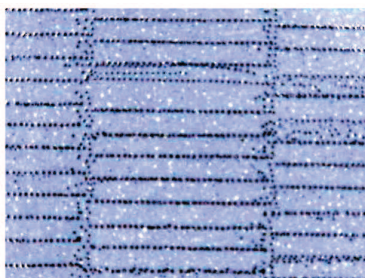

Nozzle Deflection

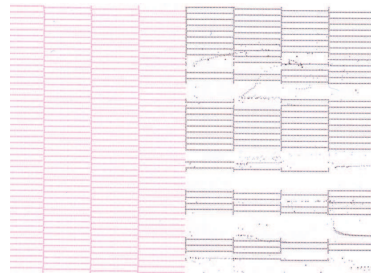

Nozzle clogging



Ink drips



Mist

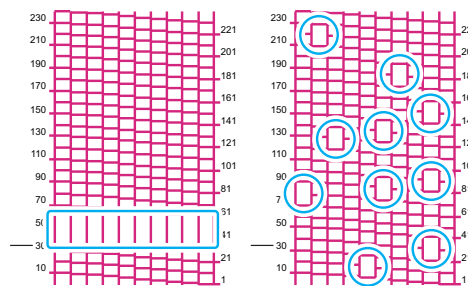

Mixed air

2.6 Head Cleaning

The following head cleaning methods are available. Choose the method based on test results. Cleaning is not possible when the [Ink Near End] or [Ink End] errors are displayed. Replace with new ink.  ["Replacing Ink"\(P. 41\)](#)

Item	Details
Soft	If the print shows a bent line (Nozzle deflection)
Normal	If the print shows a missing line (nozzle clogging)
Hard	If soft cleaning and normal cleaning fail to resolve ejection failures (e.g., nozzle clogging or deflection).

1 On the LOCAL mode screen, select [TEST PRINT/CLEANING] > [Cleaning], then press the [ENTER] key.



- The Cleaning menu is displayed.

2 Select the cleaning type, then press the [ENTER] key.

3 Run another test print and check the print results.

- Repeat the cleaning and test printing process until the print results appear normal.



- Do the following if head cleaning fails to resolve the ejection failures (e.g., nozzle clogging or deflection).
 -  ["Cap Rubber Cleaning"\(P. 94\)](#)
 -  ["Print Head Nozzle Washing"\(P. 123\)](#)
- Do the following if unusual noise occurs during cleaning.
 -  ["Abnormal noise occurs during cleaning"\(P. 126\)](#)

2.7 Auto Correction

The automatic correction function (DAS2: Dot Adjustment System2) automatically performs feed correction and dot position correction.

- 1 On the LOCAL mode screen, select [ADJUST].

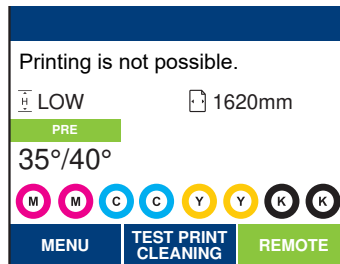

- 2 Select [Auto-correction], then press the [ENTER] key.
- 3 Select whether or not to draw the base and press the [ENTER] key.

- This screen is displayed only for ink sets with white ink.
- Applicable ink sets: LUS-210: 4C+W, 4C+CIW, ELS-170: 4C+CIW

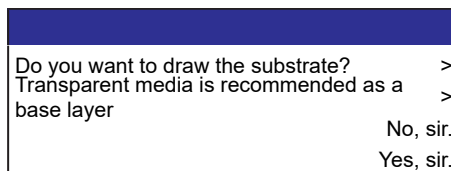

- 4 Press the [ENTER] key to start adjustment.



Correction items

- Feed Comp.
- Dot position correction (outbound, inbound, round-trip correction)
 - 600Hi
 - 900Hi (only for 4C+W or 4C+CIW)
 - 1200Hi



- Check to confirm that the media does not lift up.
- Load white and clean media.
- Media such as synthetic paper, tarpaulin, or cloth media may not be detected.
- The ink set without white ink may not be able to correct properly with colored or transparent media because the underlying surface cannot be drawn.
- Do not send RIP data from the PC during pattern printing.
- If auto-correction fails or if the adjustment is still out of alignment after auto-correction, perform the following menu manually.
 - [ADJUST] > [feed correction] "Feed Correction"(P. 69)
 - [ADJUST] > [dot position correction] "Correcting the Drop Position"(P. 71)

2.8 Feed Correction



- The recommended correction is automatic, but it should be performed when the automatic correction does not match.

Changing the media may affect the feed amount due to various factors, including the weight and thickness of the media and whether the take-up unit is used. Correct the drop position to suit the type of media used. Image defects (e.g., dark or light streaks) will result if the feed is not properly corrected.

Check beforehand

- Is media loaded? "Loading the Media"(P. 52)
- **Does the heater temperature suit the media to be used?** "Setting the Heater Temperature"(P. 64)
- For roll media, is the rear roll media free of sagging?
- When using the take-up unit, is the media mounted on the paper core of the take-up unit? "Loading the Roll Media"(P. 57)

Feed Correction Procedure

Print a correction pattern, then enter the correction value. The value corrected here will also be updated on the Media Setting menu.



- When using the take-up unit, load media on the take-up unit before correcting.

- 1 On the LOCAL mode screen, select [ADJUST].

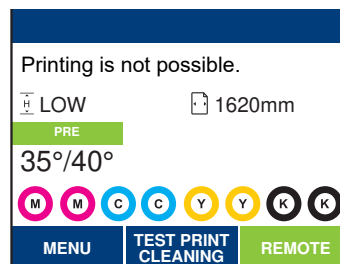

- 2 Select [Feed Comp.], then press the [ENTER] key.

- Correction pattern printing starts.

- 3 Check the print results.

- A correction value input screen appears.
- Adjust the bands so that the region between them is evenly colored.



- 4 Enter the correction value, then press the [ENTER] key.

- "+" input: Increases the separation between bands.
- "-" input: Reduces the separation between bands.
- Increment the correction value by "30" to move the bands by approximately 0.1 mm.

5 Press the [ENTER] key.

- Print another correction pattern to check.



- Once adjustment is complete, the medium will be fed to the print origin. Sagging may occur in the rear roll medium. Rewind roll media by hand to eliminate any sagging.
-

Correcting the Media Feed During Printing

You can also correct the media feed amount in REMOTE mode or during printing.

1 Press [ADJUST] in REMOTE mode or during printing.

2 Enter the correction value, then press the [ENTER] key.

- Correction value: -9999 to 9999
- The value entered here will be updated immediately.

2.9 Correcting the Drop Position



- The recommended correction is automatic, but it should be performed when the automatic correction does not match.

Changing the media and print head height and temperature changes around the print head will also alter the drop positions. Correct the drop position to suit the type of media used. Image defects (e.g., overlaid lines or blurred images) will result if the drop position is not properly corrected.

Check beforehand

- Was the print head adjusted? ["Adjusting Print Head Height"\(P. 51\)](#)
- Is media loaded? ["Loading the Media"\(P. 52\)](#)
- Does the heater temperature suit the media to be used?** ["Setting the Heater Temperature"\(P. 64\)](#)



- Load media at least 500 mm wide. You cannot print the entire pattern if media less than 500 mm wide is used.

Drop Position Correction Procedure

Print a correction pattern, then enter the correction value. The value corrected here will also be updated on the Media Setting menu. This must be adjusted for each print resolution.

- On the LOCAL mode screen, select [ADJUST].

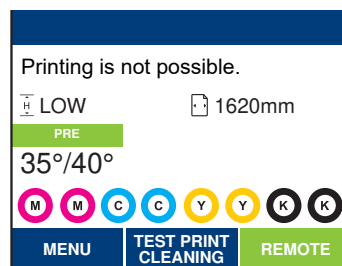

- Select [Drop.PosCorrect], then press the [ENTER] key.

- Select the resolution, then press the [ENTER] key.

- Select the resolution to be adjusted. When "All" is selected, correction patterns for all resolutions will be printed. ["Media Setting Menu"\(P. 80\)](#)



- The indicated resolutions are those in the scan direction.

- Check the print results.

- A correction value input screen appears.
- Enter the position where the two upper and lower lines coincide.

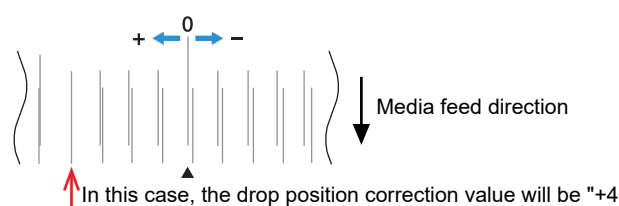

5 Enter the correction value, then press the [ENTER] key.

- Correction value: -40 to 40



- If the lines do not coincide when the correction value is within the range -40 to 40, the print head height may have been improperly adjusted. Adjust the print head height.
 ["Adjusting Print Head Height"\(P. 51\)](#)
-

6 Enter the correction value in the same way for pattern 2 and subsequent patterns.

2.10 Preparing RIP data

The explanation here applies to MIMAKI RIP software (RasterLink).



- Prepare suitable image data for printing.

1 Launch RasterLink.

- Click the icon on the PC desktop.



2 Select the image data to print.

- (1) Select [File] > [Open].
- (2) Select the desired image data, then click [Open].
 - If multiple printers are registered, select UJV200-160 from "Printer Name".

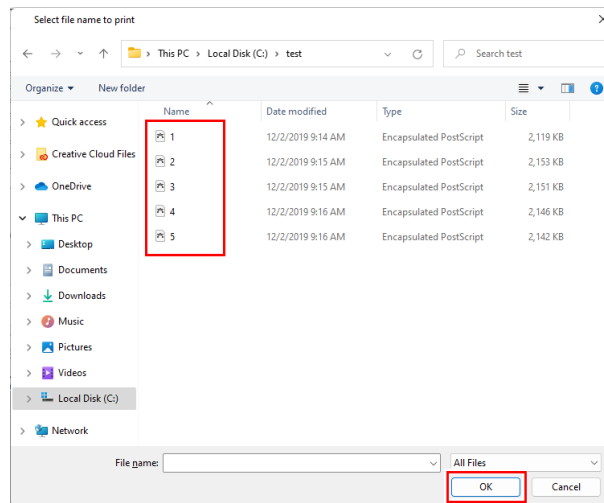

3 Select the image data imported.

- The image data is added in the tab for UJV200-160 selected in "Printer Name".

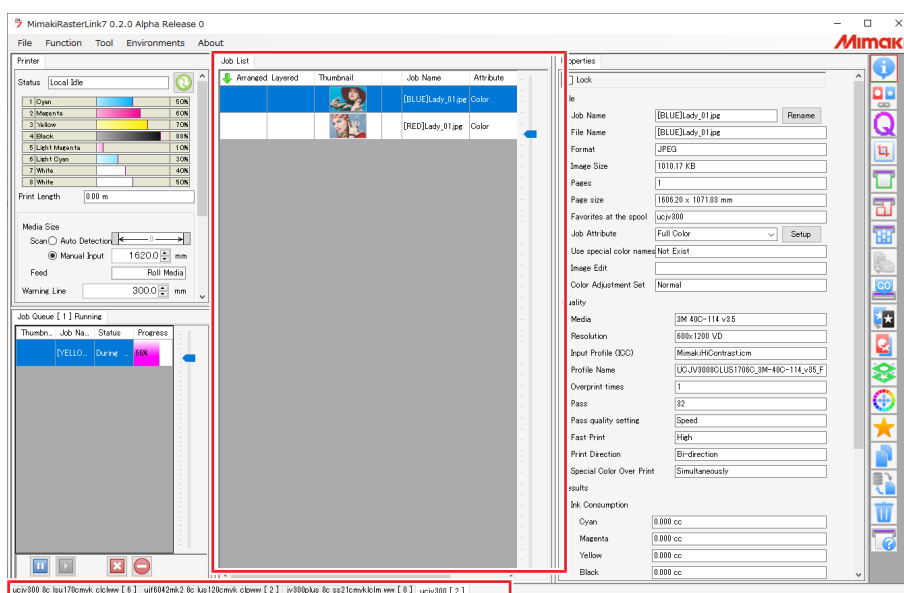

4 Edit the image.

- Specify the following settings by clicking the function icons shown on the right-hand side of the screen:

 (General Print): Specifies settings like enlargement/reduction and rotation.

 (Quality): Selects a color profile for the media and ink set loaded in this machine.



- For more information, refer to the RasterLink reference guide. <https://mimaki.com/download/software.html>
-

5 Print image data.

-  "Starting Printing"(P. 76)

(1) Click  (Execution) from the function icons on the right-hand side of the screen.

(2) Select "Immediate Print" or "RIP and Print", then click [Start].



- Media width must be reacquired after replacing media.

(1) Select the tab for, for example, UJV200-160 in the main window.

(2) Click  (Update the printer status) in the Printer tab.

2.11 Printing

Check beforehand

- Was the print head adjusted? 🛠️ "Adjusting Print Head Height"(P. 51)
- Is media loaded? 🛠️ "Loading the Media"(P. 52)
- For roll media, is the rear roll media free of sagging?
- When using the take-up unit, was the media mounted on the paper core of the take-up unit?
🛠️ "Loading the Roll Media"(P. 57)



- Condensation may form on the print head nozzle surface depending on the ambient temperature and humidity. The formation of condensation may cause ejection failures (e.g., nozzle clogging or deflection). Perform head cleaning if any ejection failures (e.g., nozzle clogging or deflection) occur during printing. 🛠️ "Head Cleaning"(P. 67)

Changing the origin

The print start position can be altered. Use the LED pointer to set the origin.

- Print origin default value
 - Feed (longitudinal, X') direction: Approx. 75 mm to rear from platen cutting slot
 - Scan (lateral, Y') direction: 15 mm from right edge of media

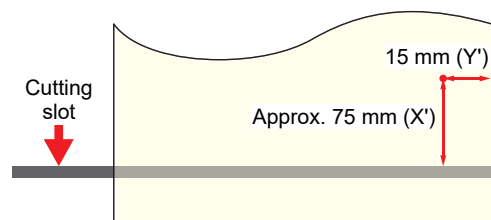

- 1 On the LOCAL mode screen, press ▲▼◀▶.**
 - The Origin Setup screen appears.
- 2 Press ▲▼◀▶ to move the origin to the desired position.**
 - The carriage moves left and right and feeds the medium.
- 3 Press the [ENTER] key.**
 - The origin is updated.

Starting Printing

1 Send the RIP data from the PC.

-  "Preparing RIP data"(P. 73)



- If the message "Attention20A Driver version" appears, install the latest Mimaki driver.
<https://mimaki.com/download/inkjet.html>

2 Start printing.

- Printing starts once RIP data is received.

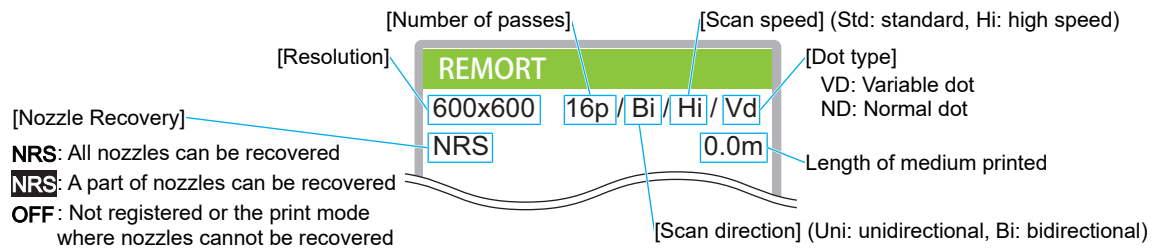

- Print speeds may differ for the same image data, depending on the width of the medium loaded, print origin position, and resolution.
- If an error occurs, the machine switches to LOCAL mode once printing is completed. Further printing is not possible.
- If there are nozzles that cannot be recovered, "Nozzle recovery not possible" will be displayed at the start of printing. If nozzle clogging is noticeable, try increasing the number of passes or changing the resolution.

Pausing Printing

1 Press [LOCAL] while printing is in progress.

- Printing is paused.
- If data is being sent from a PC, data transmission is paused at the PC.

2 Press [REMOTE].

- Printing resumes.



- No other functions can be used when printing is paused.

Stopping Printing (Data Clear)

- 1 On the LOCAL mode screen, select [DATA CLEAR].

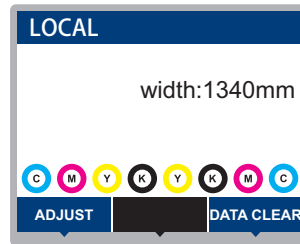

- 2 Press the [ENTER] key to clear the received data.
 - The receive buffer is cleared.

2.12 Cutting the media

- 1** On the LOCAL mode screen, press ▲▼◀▶.
 - The Origin Setup screen appears.
- 2** Press ▲▼ to feed the media to the position required for cutting.
- 3** Select [CUT].
- 4** Press the [ENTER] key.
 - The media is cut.

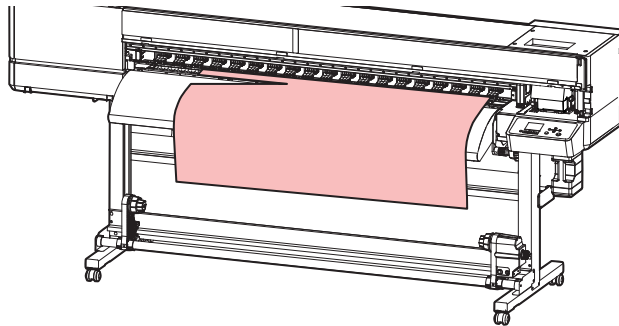

When the machine is not in use, raise the clamp lever to **separate the pinch rollers from the grit rollers**.

- Leaving the pinch rollers lowered may cause them to become deformed and prevent media from being fed correctly.
- Leaving media loaded will subject it to force from the pinch rollers, which may leave pinch roller marks on it.

Chapter 3 Setup



This chapter

This chapter describes the [MENU] functions.

Media Setting Menu	80	Function Setting Menu	87
Maintenance Menu	83	Environment Setting Menu	89
Registering Nozzle Recovery Manually	86	Machine Status Menu.....	90
Nozzle Check (Option).....	86		

3.1 Media Setting Menu

When you use the machine for the first time, the Select Use Media screen is displayed.  ["Registering the Media"](#)(P. 62)





The media Information and correction value can be saved in advance for specific media.

The user can select to prioritize the settings on the machine or the settings on the PC. Setting individual menus to "Host" prioritizes PC settings. To prioritize settings for this machine, select a setting other than "Host".



- For more information on how to specify RIP software, refer to the RIP software operating manual.

● Menu List

Item	Setting		Details
	*1	*2	
Feed Comp.	-9999 to <u>0</u> to 9999	-	Corrects the media feed amount. Print a pattern and enter the correction amount.  "Feed Correction" (P. 69)
Drop.PosCorrect	-	-	Corrects the drop position for bi-directional printing.  "Correcting the Drop Position" (P. 71)
(Resolution)	*	-	Select the resolution to be corrected. When "All" is selected, correction patterns will be printed for all resolutions. * The available resolutions vary according to the model.
(Correction Value)	-40.0 to <u>0</u> to 40.0	-	Check the pattern and enter correction values.
Auto-correction	-	-	The auto-correction function (DAS2: Dot Adjustment System2) detects a correction pattern with the sensor and automatically corrects the drop position.  "Auto Correction" (P. 68) <ul style="list-style-type: none"> • Check to confirm that the media does not lift up. • Load white and clean media. • Media such as synthetic paper, tarpaulin, or cloth media may not be detected. • Do not send RIP data from the PC during pattern printing. • If automatic correction is unsuccessful, correct the position manually. [MENU] > [Media Setting] > [Feed Comp.] or [Drop.PosCorrect]
Feed Comp.(pull-back)	-9999 to <u>0</u> to 9999	-	This adjustment must be performed before using pullback printing. Corrects the media feed amount specifically for the pullback printing function. <ul style="list-style-type: none"> • Print a pattern and enter the correction amount.  "Feed Correction"(P. 69)
UV mode	<u>ON</u> /OFF/ NoPrint	ON	Sets whether to turn on or off the UV-LED lamp. <ul style="list-style-type: none"> • ON: Turns on the lamp. • OFF: Does not turn on the lamp. • NoPrint: Turns on the lamp without printing. (Not used under ordinary conditions)
UV AdjVal	-50 to <u>0</u> to +50 %	-	The preset UV-LED lamp brightness can be altered. Check the performance (e.g. stickiness and odor) after printing. <ul style="list-style-type: none"> • Minus direction: Reduces hardness.

Item	Setting		Details
	*1	*2	
			<ul style="list-style-type: none"> Plus direction: Increases hardness.
Ionizer	OFF/ON	-	Sets the ionizer (optional).
MAPS	AUTO / MANUAL / OFF	-	<p>MAPS: Mimaki Advanced Pass System This function disperses the boundaries between passes to make feed streaks between passes less visible. Altering MAPS may alter the color. This function may be less effective with certain types of images.</p> <ul style="list-style-type: none"> This should normally be set to "AUTO". When set to "MANUAL", the following items are displayed:
Speed	50 to 100%	-	Reducing speed will make streaks less visible. However, printing will be slower.
Smoothing Level (Color)	0 to 100%	-	Increasing smoothing makes streaks less visible. Make separate settings for color and spot color (white).
Smoothing Level (Spot)			
Heater	-	-	Set the heater temperature. ☞ "Setting the Heater Temperature"(P. 64)
PRE	OFF/20 to 60 °C	-	Preheats the media before printing to suppress rapid temperature change.
OFF time	None / 0 to 90 min	-	Sets the time before turning the heater off after printing.
Media Information	-	-	Enter the media information.
Media Type	-	-	Select the media type to be used. The available media types vary depending on the model.
Media Width	-	-	Sets the media width detection method.
Detection Type	AUTO/ MANUAL		<ul style="list-style-type: none"> AUTO: The media width is automatically detected with the sensor. MANUAL: ◀ Press ▶ to set the media width manually. <ul style="list-style-type: none"> When media width cannot be detected correctly, set the media width detection method to "MANUAL".
Media Remain	-	-	The remaining roll media amount can be displayed and printed out in REMOTE mode. The print length will be displayed when leaf media is in use.
Media Remain Manage	ON/OFF	-	<ul style="list-style-type: none"> ON: An input screen appears once the media width is detected. ▲ Press ▼ to set the media length. Press the [FUNC3] key on the "Origin Setup" screen to print the date and remaining media amount. OFF: The remaining media amount is not displayed.
Length	0 to 50 to 500 m	-	Enter the roll media length.
Detail Setting	-	-	This is used to set various functions.
Vacuum Fan	Host/Weak/ Standard/ Strong	Strong	<p>Sets the force with which the medium is held down.</p> <ul style="list-style-type: none"> This can be used to prevent media jamming and print head damage caused by the media lifting up.

Item		Setting		Details
		*1	*2	
	Continuous Running	<u>ON</u> /OFF		<ul style="list-style-type: none"> • ON: The media is constantly held down under vacuum. • OFF: The media is held down by vacuum only when required, such as during printing and feeding.
	Feed Speed	<u>Host</u> /10 to 100 to 200 %	100	Sets the media feed speed. <ul style="list-style-type: none"> • Depending on print conditions, the speed may not vary for certain settings. • Setting to 100 % or more reduces the time required to complete printing but may affect print quality due to insufficient drying time.
Media Name Change		-	-	You can change the name of a setting type. The name can include alphanumeric characters or symbols.
Delete MediaInfo		-	-	Delete the set media information.

*1. The default settings are shown underlined.

*2. Settings applied if no settings can be made in the RIP software (host) or if this machine is prioritized.





*3. Displayed only when an optional lonizer is installed.

3.2 Maintenance Menu

This menu is used for maintenance actions. It also lets the user perform nozzle recovery if nozzle clogging persists even after cleaning and nozzle washing.

● Menu List

Item	Setting ^{*1}	Details
Station Maint.	-	This moves the carriage to allow station and print head maintenance.
Carriage Out	-	
Move To Platen Right End	-	Cleans around the station, including the cap, wiper, and NCU. ☞ "Cap Rubber Cleaning"(P. 94) ☞ "NCU (Option) Cleaning"(P. 97)
Move To Maint. Space	-	Cleans around the print head. ☞ "Carriage Underside Cleaning"(P. 95) ☞ "Media Sensor Cleaning"(P. 99) ☞ "DAS (automatic correction function) / Sheet width sensor cleaning"(P. 98)
Head height switching	-	Adjusts the height of the print head according to the thickness of the media.☞ "Adjusting Print Head Height"(P. 51)
Nozzle Wash	-	Washes the print head nozzle surface with maintenance liquid to resolve ejection failures (such as nozzle clogging or deflection). ☞ "Print Head Nozzle Washing"(P. 123)
Pump Tube Cleaning	-	Washes the suction pump tube (below the cap).☞ "Ink Discharge Channel Cleaning"(P. 99)
Custody Wash	-	Perform this step if the machine will not be used for extended periods. Washes nozzles and drainage channels to keep the machine operating smoothly. ☞ "When this Printer is Left Unused for a Long Time"(P. 103)
Replace Wiper	-	Use this function when replacing the wiper. Replacing the wiper resets the wiper usage counter. ☞ "When Wiper End is Displayed"(P. 106)
Cap Replacement	-	Use this function when replacing the cap. Replacing the cap resets the cap usage time stored in the machine. ☞ "Cap Replacement"(P. 109)
Test Printing	-	Print a test pattern to confirm that the ink prints correctly. Perform head cleaning if you observe any ejection failures (e.g., nozzle clogging or deflection). ☞ "Test Printing"(P. 65)
Scan Dir.		Prints repeatedly in the horizontal direction.
Feed Dir.		Feeds the medium and prints repeatedly in the longitudinal direction.
Spot Color Check		Checks for white ink.
Cleaning	-	Several head cleaning methods are available. Choose the method based on test results. ☞ "Head Cleaning"(P. 67)
Soft		If the print shows bent lines (nozzle deflection)
Normal		If the print shows missing lines (nozzle clogging)
Hard		If soft cleaning and normal cleaning fail to resolve ejection failures (e.g., nozzle clogging or deflection).

Item	Setting *1	Details
Nozzle Recovery	-	Allows other nozzles to be used for printing if maintenance actions like nozzle washing fail to resolve print defects (e.g., nozzle clogging, deflection).
Print	-	Prints a pattern to check nozzle condition and register the nozzle.  "Registering Nozzle Recovery Manually"(P. 86)
Entry	-	Registers the nozzle without printing a pattern.
Reset	-	Initializes the details set.
Test Printing	ON/OFF	Sets whether to perform nozzle recovery before test printing.
Nozzle Check *2	-	 "Nozzle Check (Option)"(P. 86)
Printing Check	ON/OFF	Performs nozzle clogging detection before printing starts.
Check Interval	-	Sets the nozzle clogging detection timing.
Length	0.1 to 30.0 to 100.0 m	Performs nozzle clogging detection after the length set is reached and before the next print starts.
File	1 to 30 to 1,000 files	Performs nozzle clogging detection after the preset number of files has been printed and before the next print starts.
Continuation Print	Stop/ Continuous	Select whether to stop or continue printing if "Nozzle clogging" is detected.
Action	Off/1 to 10 to 100	Performs nozzle recovery (cleaning followed by nozzle checking) if "nozzle clogging" is detected.
Cleaning	Soft/ Normal/ Hard	Sets the cleaning type.
Retry Count	0 to 3 times	Performs nozzle recovery (cleaning followed by nozzle checking) for the specified number of times.
Auto Nozzle Recovery	ON/OFF	Performs nozzle recovery automatically if "nozzle clogging" is detected. See below if you wish to perform nozzle recovery manually.  "Registering Nozzle Recovery Manually"(P. 86)
Judgment Condition	OFF / 1 to 32 nozzles	Set the number of nozzles to be detected as clogged before "nozzle clogging" is detected. Up to 16 nozzles per row can be set. The next print will not start if "nozzle clogging" is detected during continuous printing.
Auto Maint.	-	Sets various maintenance actions to be performed automatically. Set the interval between individual maintenance actions. <ul style="list-style-type: none"> If the warning message "Replace Wasteinktank" appears, the automatic maintenance function is disabled.  "Waste Ink Tank Replacement"(P. 115)
Refresh	0.5 to 4.0 h	Sets the conditions to refresh the head after the preset time has elapsed.
Cleaning Interval	1 to 24 h	Sets the conditions to perform head cleaning after the preset time has elapsed.
Type	Soft/ Normal/ Hard	Sets the cleaning type for head cleaning.
Print Maint.	-	Sets the maintenance to be performed automatically midway during printing.

Item	Setting ^{*1}	Details
Auto Cleaning	-	Sets the conditions to perform head cleaning after the preset number of files are printed.
Setup	File/ Length/ <u>Time</u> / OFF	Sets the conditions to perform head cleaning.
Interval	-	Sets head cleaning intervals.
(File)	1 to <u>10</u> to 1,000	Cleaning starts when the set number of files is exceeded.
(Length)	0.1 to <u>1.0</u> to 100.0 m	Cleaning starts after the length set is reached and before the next print starts.
(Time)	0.5 to <u>4.0</u> to 30 h	Cleaning starts after the print time set is reached and before the next print starts.
Type	Soft/ <u>Normal</u> / Hard	Sets the cleaning type for head cleaning.
Cleaning Check ^{*2}	ON/ <u>OFF</u>	Sets whether nozzle checking is performed after head cleaning is completed.
Interval Wiping	<u>OFF</u> /3 to 255 min	Wiping starts when the set print time is exceeded.
White Maintenance	-	Prevents ink sedimentation inside the ink routes. <ul style="list-style-type: none"> Use this when uneven color occurs for the white ink.
Waste Ink Tank	-	Resets or corrects the waste ink tank usage count. 🗑️ "Waste Ink Tank Replacement"(P. 115)
Reset Waste Ink Volume	-	Resets the waste ink tank usage count. 🗑️ "Waste Ink Tank Replacement"(P. 115)
Adjust Waste Ink Volume	-	Corrects the waste ink tank usage count. 🗑️ "When "Check Waste Ink Tank" message appears"(P. 115)
Air PG	-	Expels any air in the ink paths. <ul style="list-style-type: none"> Use this if Ink End is still displayed after ink replacement. Use this in case of considerable nozzle clogging with white ink (dropouts).
Ink Supply Maint.	-	<ul style="list-style-type: none"> Use this if a "Less Supply" error occurs. Use this if an ink supply error occurs in the white ink path.

*1. The default settings are shown underlined.

*2. Displayed only when an optional NCU is installed.

Registering Nozzle Recovery Manually

Allows other nozzles to be used for printing if maintenance actions like nozzle washing fail to resolve ejection failures (e.g., nozzle clogging or deflection).



- Nozzle recovery can be specified for up to 20 nozzles per row. The time taken for printing remains unchanged even when nozzle recovery is set.



- Load media at least 500 mm wide. You cannot print the entire pattern if media less than 500 mm wide is used.

- 1 Position the media.**
- 2 On the LOCAL mode screen, select [MENU] > [Maintenance], then press the [ENTER] key.**
 - The Maintenance menu is displayed.
- 3 Select [Nozzle Recovery] > [Print], then press the [ENTER] key.**
 - Print a nozzle recovery pattern.
 - The Select Entry Nozzle screen appears once printing is complete.
- 4 Select the "head number and nozzle row" for nozzle recovery, then press the [ENTER] key.**
- 5 Enter the "nozzle number" for nozzle recovery, then press the [ENTER] key.**
 - Select the entry number before entering the nozzle number.
 - Nozzle recovery is set.
- 6 Press the [ENTER] key once entry is complete.**



- Select [Maintenance] > [Nozzle Recovery] > [Test Print], then select "ON" to perform nozzle recovery and test printing. 🗨️ ["Test Printing"\(P. 65\)](#)

Nozzle Check (Option)

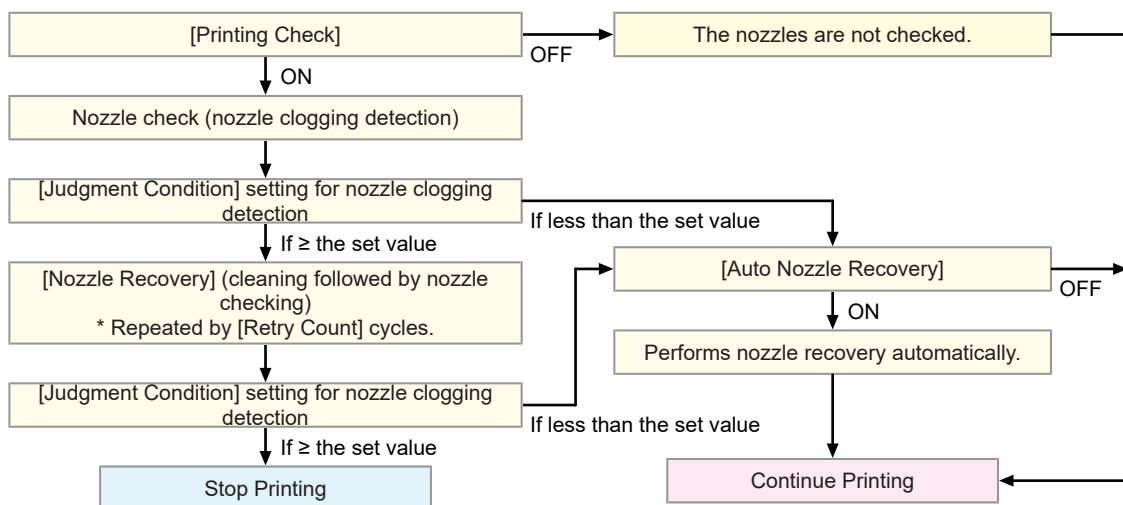

This is used to check for nozzle clogging before printing starts. Sets whether to perform maintenance functions automatically if nozzle clogging is detected.



3.3 Function Setting Menu

This is used to set various operations to ensure optimal machine performance.

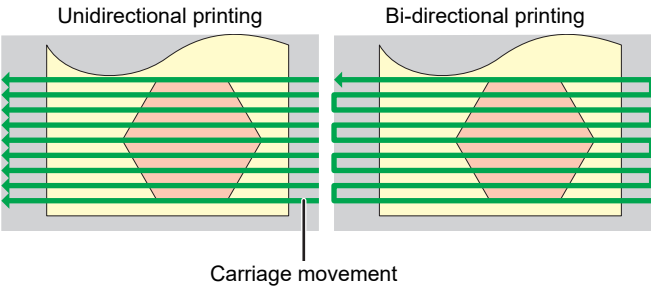
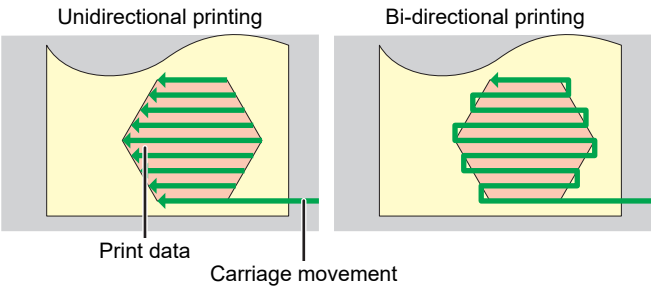
● Menu List

Item	Setting *1	Details
Logical Seek	Host /OFF/ON	<p>Sets the range of carriage movement.</p> <ul style="list-style-type: none"> • OFF: Machine size area  <p>Carriage movement</p> <ul style="list-style-type: none"> • ON: Print data area  <p>Print data Carriage movement</p>
Take-up Unit	-	Sets the take-up unit operation.
Take-up Unit	ON /OFF	Set to "OFF" if the take-up unit is not used.
Take-up SW	Continuous / Temporary	<p>Sets the function performed by the ON/OFF button on the take-up unit.</p> <p> "Take-up unit"(P. 53)</p> <ul style="list-style-type: none"> • Continuous: Press the button to start/stop the take-up unit. • Temporary: The take-up unit operates only while the button is pressed. The unit stops when the button is released.
Power Setting	-	Sets the times to turn the power on and off automatically.
Auto Power-off	5 to 15 to 60 min	Sets the time until the power is automatically turned off.
Auto Power-on	-	Sets the time to automatically turn on the power.
Setup	ON /OFF	Sets whether to turn on or off the power.
Time	0:00 to 23:59	Sets the time to turn on the power.
Day	Monday to Sunday	Sets whether to turn on or off the power on each day of the week.
Nozzle Check *2	ON /OFF	Automatically executes the nozzle check function when the machine is started with auto power-on. Performs nozzle recovery (cleaning followed by nozzle checking) if "nozzle clogging" is detected.
Cleaning	Soft /Normal/ Hard	Sets the cleaning type.

Item		Setting ^{*1}	Details
	Retry Count	<u>0</u> to 3 times	Performs nozzle recovery (cleaning followed by nozzle checking) for the specified number of times.
WhiteSpace Setting		-	Sets the offset value from the media left and right standard margins (15 mm). <ul style="list-style-type: none"> The left and right margins should be set to at least -5 mm when using the media holder. This eliminates the risk of printing on top of the media holder. The Mimaki RIP software (RasterLink) does not allow the user to specify margins. If the machine is set to "Host", the offset value will be "0 mm" for the left and right margins.
	Margin	-	
	Margin/Left	<u>Host</u> /-10 to 85 mm	
	Margin/Right		
	Space Btwn PP.	<u>None</u> /10 to 500 mm	The space between prints can be eliminated for continuous printing. <ul style="list-style-type: none"> Reducing the space length may cause media sagging, resulting in discrepancies in the distance the media is fed. The actual space may be wider than set, depending on the size of image data and number of passes in the feed direction.
	Space Feed Mode	<u>Intermittent</u> / Continuous	Alters the feed method for blank space included in the image data. <ul style="list-style-type: none"> Intermittent: Uses intermittent feeding based on the timing of a fraction of the pass. Continuous: Feeds forward by skipping blank parts.
	View Feed	<u>ON</u> /OFF	Sets whether or not to feed the media forward to view the print results—for example, during test printing.
	Feeding Before Cut	<u>ON</u> /OFF	Sets whether to feed media before cutting the media.
	Auto Remote	<u>ON</u> /OFF	Sets whether to automatically switch to REMOTE mode and start printing if data is received locally.

*1. The default settings are shown underlined.

*2. Displayed only when an optional NCU is installed.

3.4 Environment Setting Menu

This is used to set various operations to ensure optimal machine performance.

● Menu List

Item	Setting ^{*1}	Details
LANGUAGE	<u>English</u> / 日本語 / Deutsch / Português / Español / Italiano / Korean	Sets the display language.
Time Set	-20 to <u>0</u> to +4 h	Sets the current time and date. (With respect to JST) <ul style="list-style-type: none"> This can be set within the range of -20 to +4 hours.
Key Buzzer	<u>ON</u> /OFF	Sets an audible tone when keys are pressed. <ul style="list-style-type: none"> Audible signals indicating errors, warnings, and operation end cannot be muted, even if "OFF" is selected for this setting.
Unit Setting	-	Set the display units.
Temp.	<u>°C</u> /°F	Sets the display unit for temperature (Celsius/Fahrenheit).
Length	<u>mm</u> /inch	Sets the display units for length and area. <ul style="list-style-type: none"> Some items are displayed in "mm" even if "inch" is selected.
Network	-	Sets the network address. The machine must be restarted to enable this setting.
Check IP Address	-	Displays the machine's current IP address. <ul style="list-style-type: none"> It may take some time to determine the IP address. If the IP address cannot be determined, the display will indicate "0.0.0.0".
Check MAC Address	-	Displays the machine's current MAC address.
DHCP	<u>ON</u> /OFF	Select "ON" to use the IP address assigned by the DHCP server.
AutoIP	<u>ON</u> /OFF	Select "ON" to use the IP address set by the AutoIP protocol. Note that DHCP takes priority if DHCP is set to "ON".
Remote Control	-	An application (MRA: Mimaki Remote Access) is required to use the remote control function. MRA is a remote access tool installed on a computer or smartphone that allows viewing of product information and panel operation from a remote location away from the machine (within the same network segment).
Remote Control	<u>Enable</u> /Disable	Enable/disable remote control.
PIN code	<u>0000</u> to 9999	Enter the same PIN code as MRA. The PIN code is used for authentication between the machine and MRA. <ul style="list-style-type: none"> When the machine is set to "0000", MRA can access the machine with any PIN code.
KeyLife	5 to <u>30</u> to 120 min	Sets the time interval before disconnecting the machine and MRA if no operations are performed using MRA.
Machine Reset	-	Initializes the details set.

*1. The default settings are shown underlined.

3.5 Machine Status Menu

This is used to check machine information.

● Menu List

Item		Details
Usage	Roll Wiper Remain	Displays the remaining amount of cloth wiper. <ul style="list-style-type: none"> To reset the remaining amount of cloth wiper, press the [FUNC2] key while the amount is displayed.
	Waste Ink Tank	Displays the approximate level of waste ink in the waste ink tank as a percentage. <ul style="list-style-type: none"> To reset waste ink levels, press the [FUNC1] key while the level is displayed.
	Print Length	Displays the total length printed.
	Print Area	Displays the total area printed.
	Use Time	Displays the total time the power has been turned on.
	UV Lamp	Displays the total time the UV-LED lamp has been used.
	Capping Use Days	Displays the number of days since the cap was replaced.
Version		Displays the machine firmware and other versions.
Error History		Displays the error and warning history. <ul style="list-style-type: none"> These are listed in chronological order. Use the keys to cycle through occurrence time/date and error/warning information.
List		This is used to print machine information.

Chapter 4 Maintenance



This chapter

To ensure years of precise performance, maintain the machine periodically based on frequency of use.

Read the maintenance precautions thoroughly before maintaining this product.

Maintenance Precautions	92	Replacement of Consumable Item	105
Maintenance Methods	93	Consumable Item Replacement Timing	105
Maintenance Items and Timing	93	Cloth Wiper Replacement	106
Ink Maintenance	94	Cap Replacement	109
Cap Rubber Cleaning	94	Replacing the Absorber Around the Station	111
Carriage Underside Cleaning	95	Media Holder Replacement	112
Cloth Wiper Area Cleaning	96	Media Cutter Replacement	114
NCU (Option) Cleaning	97	Waste Ink Tank Replacement	115
DAS (automatic correction function) / Sheet width sensor cleaning	98	Ink bottle cap replacement	118
Ink Discharge Channel Cleaning	99		
Media Sensor Cleaning	99		
Media Cutter Cleaning	100		
Media Holder Cleaning	101		
Jam Sensor Detecting Plate Cleaning	102		
Platen Cleaning	102		
Cover (Exterior) Cleaning	103		
When this Printer is Left Unused for a Long Time	103		

4.1 Maintenance Precautions



- This machine includes parts that must be replaced periodically. We therefore recommend taking out a maintenance contract. Carry out maintenance periodically and replace consumable items to prevent quality defects and accidents.

⚠ WARNING



- Clean periodically. Debris and dust will accumulate on electrical components when the machine is used for extended periods. There is a risk of failure, electric shock, or fire due to current leakage.
- Do not clean by blowing—e.g., avoid using air blowers. Doing so may lead to failure, electric shock, or fire involving the machine if airborne debris or dust gets inside electrical components. Wipe using a soft cloth soaked in diluted neutral detergent and thoroughly wrung out. A vacuum cleaner may also be used for cleaning.



- Be careful to prevent liquids from getting inside the machine. Otherwise there is a risk of failure, electric shock, or fire.

⚠ CAUTION



- For heavy soiling, wipe using a soft cloth soaked in diluted neutral detergent and thoroughly wrung out.



- Pay close attention to ventilation and be sure to wear safety glasses, gloves, and a mask when handling ink, maintenance liquid, waste ink, or other solutions used with the machine. Leaking ink may adhere to the skin or get into the eyes or mouth.

















NOTICE



- Never touch the print head nozzle surface. Do not allow water or alcohol to come into contact with the print nozzle surface. This will increase the risk of machine failure or ejection failures (e.g., nozzle clogging or deflection).
- Do not use cotton swabs to clean around the head or carriage. Fibers from cotton swabs may adhere to the head nozzle surface and lead to ejection failures (e.g., nozzle clogging or deflection).
- Do not splash ink or maintenance liquid on the covers. Exposure to splashing ink or maintenance liquid may damage or deform the cover.
- Do not use benzine, thinner, or any chemical agent containing abrasives. Use of these chemicals may result in damage to or deformation of parts.
- Do not move the carriage by hand. To move the carriage, use the carriage out function on the menu.

4.2 Maintenance Methods

Maintenance Items and Timing

Timing	Item
Every three days, at the start of the work	Shake the ink.  "Ink Maintenance"(P. 94)
At the end of the week's work	Clean the cap rubber.  "Cap Rubber Cleaning"(P. 94)
	Clean the underside of the carriage.  "Carriage Underside Cleaning"(P. 95)
	Check the waste ink levels in the waste ink tank.  "When "Check Waste Ink Tank" message appears"(P. 115)
	Clean around the wiper.  "Cloth Wiper Area Cleaning"(P. 96)
Every month	Clean the NCU. (NCU is optional.)  "NCU (Option) Cleaning"(P. 97)
	Clean the DAS sensor.  "DAS (automatic correction function) / Sheet width sensor cleaning"(P. 98)
	Clean the ink discharge channel.  "Ink Discharge Channel Cleaning"(P. 99)
	Clean the media sensor.  "Media Sensor Cleaning"(P. 99)
	Clean the media cutter.  "Media Cutter Cleaning"(P. 100)
	Clean the media holder.  "Media Holder Cleaning"(P. 101)
	Clean the jam sensor detecting plate.  "Jam Sensor Detecting Plate Cleaning"(P. 102)
	Clean the platen.  "Platen Cleaning"(P. 102)
	Clean the cover (exterior).  "Cover (Exterior) Cleaning"(P. 103)
When not used for more than a week	Clean the cap and wash the ink discharge channels. After cleaning, store without turning off the main power supply.  "When this Printer is Left Unused for a Long Time"(P. 103)

Items Required for Maintenance

To order replacement consumable items, contact your local dealer or our service office. For more information on consumable items, refer to our website (<https://mimaki.com/supply/inkjet.html>).



- Do not store consumable items in locations where children may enter.

Ink Maintenance

If ink constituents are sedimented, the ink density may become uneven. We recommend shaking the Ink bottle periodically to keep printing consistent.

UV ink: once a month.

White ink: once a day.

● Shake the Ink bottle

1 Shake the Ink bottle to the left and right slowly at least 20 times.

- Tighten the ink bottle lid securely, then shake the bottle slowly from left to right to ensure that the ink moves inside, holding the ink bottle lid with a piece of recommended non-woven fabric.

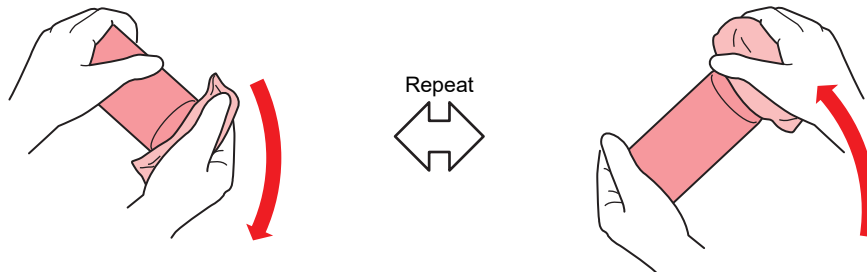

- Shake slowly. If the bottle is shaken too violently, ink may leak out or the air mixed in the ink may cause nozzle clogging.
- If the ink bottle is partially used, tilt it slowly until the ink bottle is upright.

Cap Rubber Cleaning

The cap prevents the print head nozzle surface from drying out. Continuing to use a dirty cap may affect ink take-up and lead to ejection failures (such as nozzle clogging or deflection).



- Be careful to avoid leaving fragments from the cleaning stick behind when cleaning. These fragments will increase the risk of ejection failures (e.g., nozzle clogging or deflection).

1 On the LOCAL mode screen, select [MENU] > [Maintenance], then press the [ENTER] key.

- The Maintenance menu is displayed.

2 Select [Station Maint.] > [Carriage Out] > [Move To Platen Right End], then press the [ENTER] key.

- The carriage moves over the platen.

3 Open the front cover.

4 Clean the cap rubber.

- Wipe off any ink and dust adhering using a cleaning stick moistened with maintenance liquid. Wipe off the maintenance liquid. Make sure none remains.
- Clean the areas indicated in red (the entire interior and exterior of the cap rubber and the tabs) in the diagram.

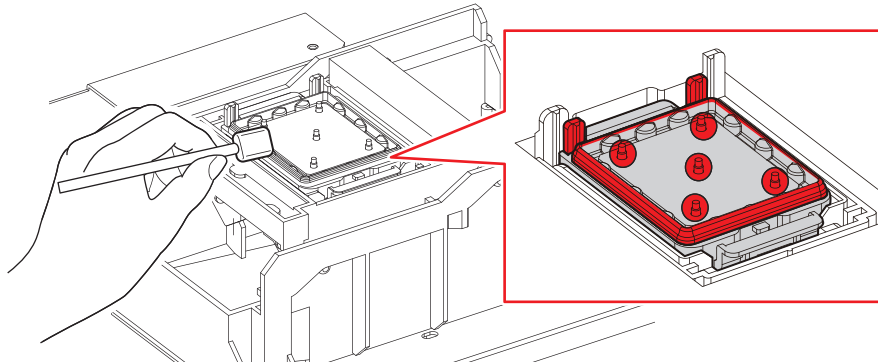

5 Once cleaning is complete, close the cover, then press the [ENTER] key.

Carriage Underside Cleaning

The underside of the carriage becomes coated with ink wiped off by the wiper. Continuing to use the dirty carriage underside will rub dried ink and attached dust on to the media, resulting in contaminated prints.

The print head uses an extremely delicate mechanism. Take great care when handling it.



- Be careful to avoid leaving fragments from the cleaning stick behind when cleaning. These fragments will increase the risk of ejection failures (e.g., nozzle clogging or deflection).

1 On the LOCAL mode screen, select [MENU] > [Maintenance], then press the [ENTER] key.

- The Maintenance menu is displayed.

2 Select [Station Maint.] > [Carriage Out] > [Move To Maint. Space], then press the [ENTER] key.

- The carriage moves to the maintenance space.

3 Open the maintenance cover (left side).

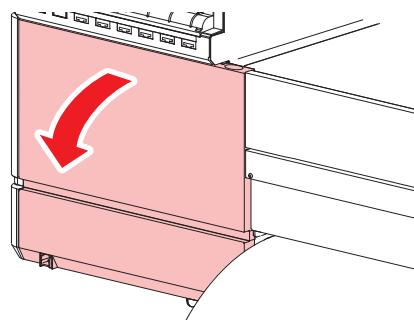

4 Clean around the print head.

- Wipe off any ink and dust adhering using a cleaning stick moistened with maintenance liquid. Wipe off the maintenance liquid. Make sure none remains.

Clean the print head sides using a cleaning stick.

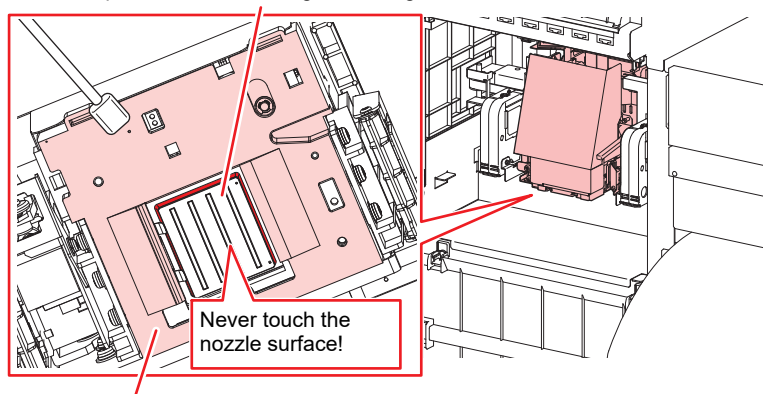

Clean using a cleaning stick or soft cloth.



- Never touch the print head nozzle surface.

5 Once cleaning is complete, press the [ENTER] key.

- The carriage moves back to its original position.

6 Close the maintenance cover.

Cloth Wiper Area Cleaning

The wiper wipes off ink adhering to the print head nozzle surface. Using a dirty wiper with dried ink or dust on it may cause the wiper to rub against the nozzle surface and lead to ejection failures (such as nozzle clogging or deflection).



- Be careful to avoid leaving fragments from the cleaning stick behind when cleaning. These fragments will increase the risk of ejection failures (e.g., nozzle clogging or deflection).

1 On the LOCAL mode screen, select [MENU] > [Maintenance], then press the [ENTER] key.

- The Maintenance menu is displayed.

2 Select [Station] > [Carriage Out] > [Move To Platen Right End], then press the [ENTER] key.

- The carriage moves over the platen.

3 Open the front cover.

4 Clean the wiper unit cover.

- Wipe off any ink and dust adhering using a cleaning stick moistened with maintenance liquid. Wipe off the maintenance liquid. Make sure none remains.

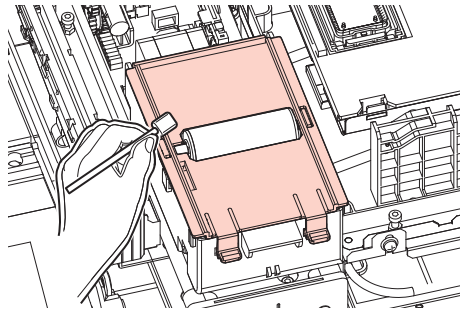

- Be careful to avoid splashing maintenance liquid on the cloth wiper.

5 Once cleaning is complete, close the cover, then press the [ENTER] key.

NCU (Option) Cleaning

The NCU uses a sensor to monitor the ink droplets ejected from the print head nozzles. Continuing to use the dirty NCU may prevent the nozzle check function from operating correctly.



- Be careful to avoid leaving fragments from the cleaning stick behind when cleaning. These fragments will increase the risk of ejection failures (e.g., nozzle clogging or deflection).

1 On the LOCAL mode screen, select [MENU] > [Maintenance], then press the [ENTER] key.

- The Maintenance menu is displayed.

2 Select [Station Maint.] > [Carriage Out] > [Move To Platen Right End], then press the [ENTER] key.

- The carriage moves over the platen.

3 Open the front cover.

4 Clean the NCU.

- Wipe off any ink and dust adhering using a cleaning stick moistened with maintenance liquid. Wipe off the maintenance liquid. Make sure none remains.



- Insert the cleaning stick as far as the line shown in the illustration.

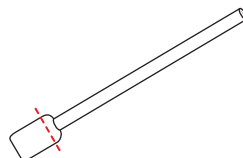

5 Once cleaning is complete, close the cover, then press the [ENTER] key.

DAS (automatic correction function) / Sheet width sensor cleaning

The DAS sensor is located on the carriage underside. If dust or debris accumulates on the sensor, DAS (Media Setting Menu) may not function.

- 1** On the **LOCAL** mode screen, select **[MENU] > [Maintenance]**, then press the **[ENTER]** key.
 - The Maintenance menu is displayed.
- 2** Select **[Station Maint.] > [Carriage Out] > [Move To Maint. Space]**, then press the **[ENTER]** key.
 - The carriage moves to the maintenance space.
- 3** Open the maintenance cover (left side).

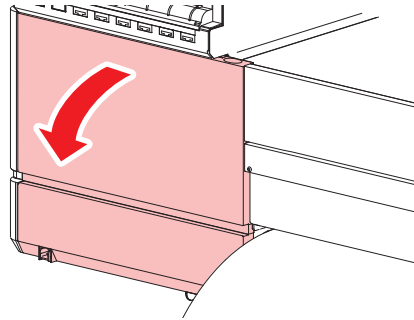

- 4** Clean the DAS sensor.
 - Wipe clean using cotton swabs or a soft cloth.

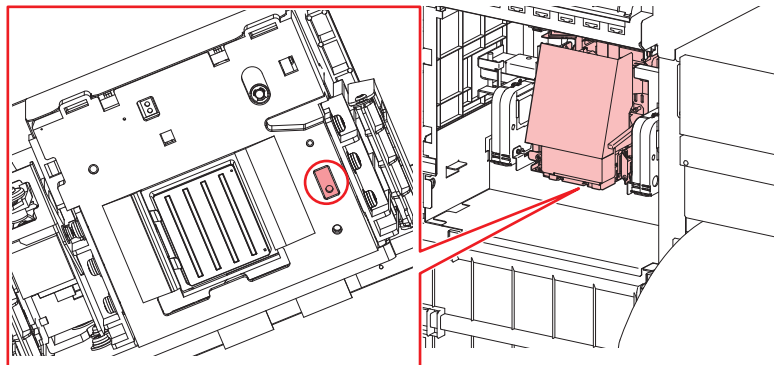

- For heavy soiling, wipe using a soft cloth soaked in diluted neutral detergent and thoroughly wrung out.

- 5** Once cleaning is complete, press the **[ENTER]** key.
- 6** Close the maintenance cover.

Ink Discharge Channel Cleaning

Clean the ink discharge channel regularly to prevent clogging of the ink discharge channel below the cap.

- 1** On the LOCAL mode screen, select [MENU] > [Maintenance], then press the [ENTER] key.
 - The Maintenance menu is displayed.
- 2** Select [Station Maint.] > [Pump tube cleaning], then press the [ENTER] key.
- 3** Open the front cover.
- 4** Fill the cap with maintenance liquid.



- Use a syringe to draw up some maintenance liquid and fill until it almost overflows from the cap.

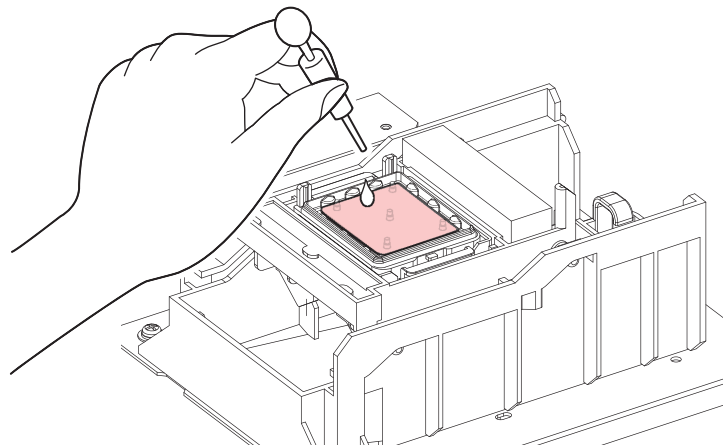

- 5** Close the maintenance cover, then press the [ENTER] key.
 - Pump tube (ink discharge channel below the cap) washing starts.

Media Sensor Cleaning

There is a media sensor located on the rear cover. The media cannot be detected correctly if dust or debris accumulates on the sensors. Remove any debris using cotton swabs or a soft cloth.

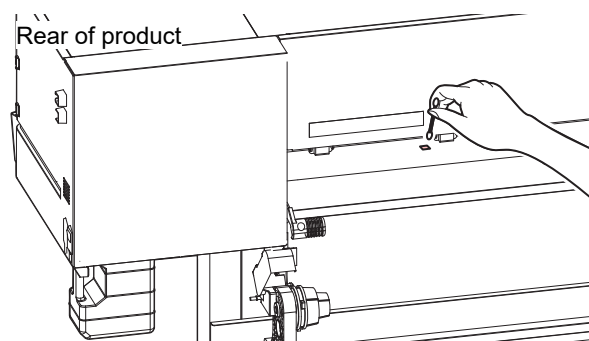

Media Cutter Cleaning

Continuing to use a dirty media cutter may cause dust to collect on the head nozzle surface or the cutter blade to grow dull.



- Avoid touching the cutter blade. Failure to do so may result in injury.

- 1 On the **LOCAL** mode screen, select **[MENU] > [Maintenance]**, then press the **[ENTER]** key.
 - The Maintenance menu is displayed.
- 2 Select **[Station Maint.] > [Carriage Out] > [Move To Platen Right End]**, then press the **[ENTER]** key.
 - The carriage moves over the platen.



- The carriage can be moved by hand. Move the carriage slowly to a position allowing easy access while working.

- 3 Open the front cover.
- 4 Remove the media cutter.

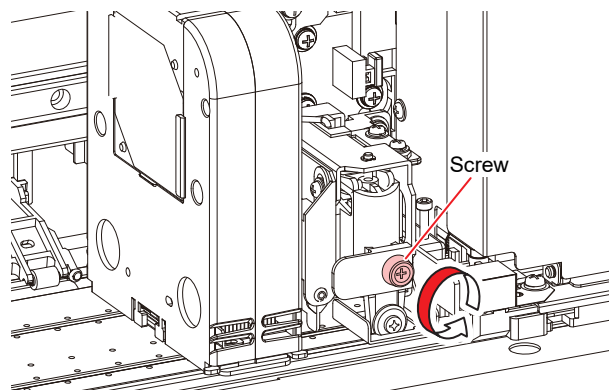

- 5 Clean both sides of the media cutter.
 - Wipe off any adhesive paste, ink and dust adhering using a cleaning stick moistened with industrial alcohol. Wipe off any industrial alcohol so that none remains.

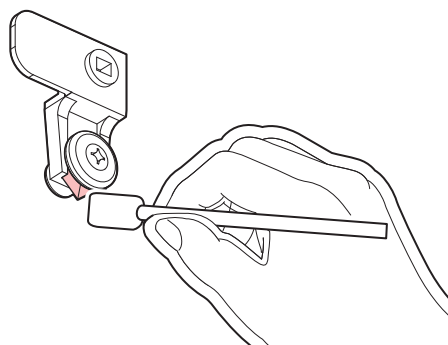

- 6 Return the media cutter to its original position.



- Tighten the screw securely. A loose screw may cause cutter or platen damage.

7 Check the position of the media cutter.

- Lift up the media cutter by hand if it has dropped down.

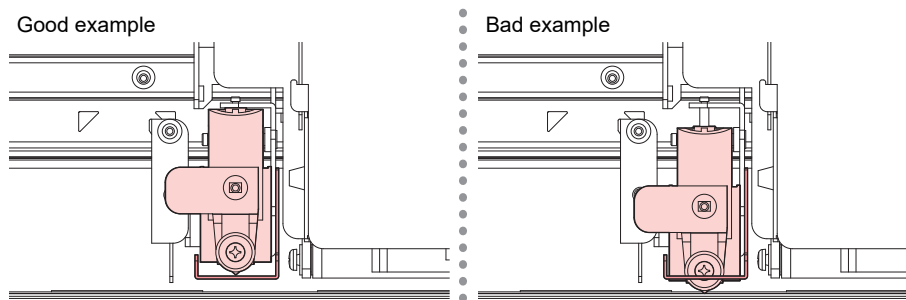

8 Once cleaning is complete, close the cover, then press the [ENTER] key.

Media Holder Cleaning

Continuing to use a dirty media holder will prevent correct media detection or proper feeding of the media. It will also cause dried ink and attached dust to rub against the head nozzle surface and lead to ejection failures (e.g., nozzle clogging or deflection).

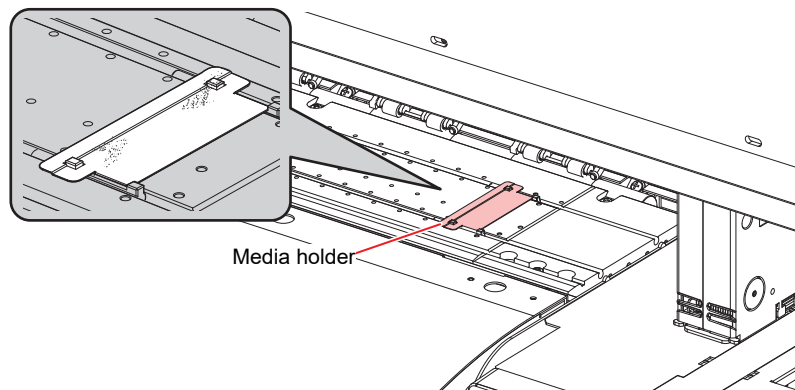

- Turn off the main power supply and unplug the power cable before carrying out maintenance.



- Be careful to prevent liquids from getting inside the machine. Otherwise there is a risk of failure, electric shock, or fire.



- For heavy soiling, wipe using a soft cloth soaked in diluted neutral detergent and thoroughly wrung out.

Jam Sensor Detecting Plate Cleaning

Continuing to use the dirty carriage underside will rub dried ink and attached dust on to the media, resulting in contaminated prints.

- 1** On the **LOCAL** mode screen, select **[MENU] > [Maintenance]**, then press the **[ENTER]** key.
 - The Maintenance menu is displayed.
- 2** Select **[Station Maint.] > [Carriage Out] > [Move To Maint. Space]**, then press the **[ENTER]** key.
 - The carriage moves to the maintenance space.
- 3** Open the front cover.
- 4** Clean the jam sensor detecting plate.
 - Clean the jam sensor detecting plate underside at the left and right sides of the carriage.
 - Wipe off any ink and dust adhering using a cleaning stick moistened with maintenance liquid. Wipe off the maintenance liquid. Make sure none remains.

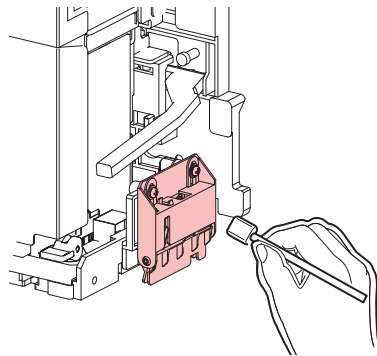

- 5** Once cleaning is complete, press the **[ENTER]** key.

Platen Cleaning

Continuing to use the dirty platen will prevent proper feeding of the media. It will also cause dried ink and attached dust to rub against the head nozzle surface and lead to ejection failures (e.g., nozzle clogging or deflection).



- Turn off the main power supply and unplug the power cable before carrying out maintenance.



- Be careful to prevent liquids from getting inside the machine. Otherwise there is a risk of failure, electric shock, or fire.



- The grooves in which the media holder slides and the media is cut are susceptible to dust accumulation. Remove any debris carefully.



- For heavy soiling, wipe using a soft cloth soaked in diluted neutral detergent and thoroughly wrung out.

Cover (Exterior) Cleaning

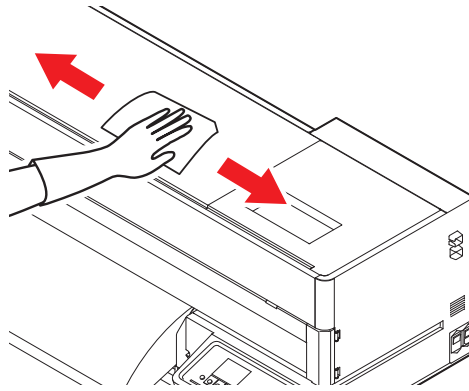

- Be careful to prevent liquids from getting inside the machine. Otherwise there is a risk of failure, electric shock, or fire.



- For heavy soiling, wipe using a soft cloth soaked in diluted neutral detergent and thoroughly wrung out.

When this Printer is Left Unused for a Long Time

Clean as follows if the product is not used for one week or longer:

Check beforehand

Is [Near End] or [Ink End] displayed?

- Maintenance liquid and ink is aspirated during the washing operation. Washing is not possible if an error occurs during this process. Replace with new ink.



- Do not turn off the main power supply. Turning off the main power supply will disable the automatic maintenance function (including nozzle clogging prevention function and ink discharge channel cleaning function). This increases the risk of ejection failures (such as nozzle clogging or deflection).

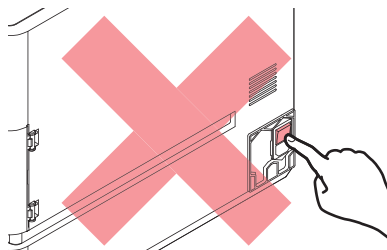

- Do not leave media loaded on the platen. This may leave irregularities or ripples in the media.



When the machine is not in use, raise the clamp lever to **separate the pinch rollers from the grit rollers**.

- Leaving the pinch rollers lowered may cause them to become deformed and prevent media from being fed correctly.
- Leaving media loaded will subject it to force from the pinch rollers, which may leave pinch roller marks on it.



- Perform the following if the "Check Waste Ink Tank" message appears on the display.
 ["Waste Ink Tank Replacement"\(P. 115\)](#)

- 1** On the LOCAL mode screen, select [MENU] > [Maintenance], then press the [ENTER] key.
 - The Maintenance menu is displayed.
- 2** Select [Station Maint.] > [Custody Wash], then press the [ENTER] key.
 - The carriage moves over the platen.
- 3** Open the front cover.
- 4** Clean the wiper.
 - Wiper Cleaning
- 5** Clean the cap rubber.
 -  ["Cap Rubber Cleaning"\(P. 94\)](#)
- 6** Once cleaning is complete, press the [ENTER] key.
- 7** Fill the cap with maintenance liquid.



- Use a syringe to draw up some maintenance liquid and fill until it almost overflows from the cap.

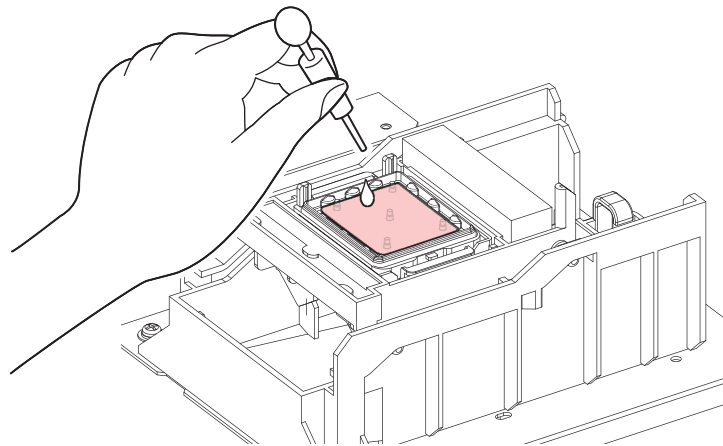

- 8** Close the gear cover.
- 9** Press the [ENTER] key.
 - Cleaning is performed automatically once print nozzle washing has ended.
 - [Please wait] is displayed.
- 10** When [Maintenance liquid Fill the liquid.] appears again, open the maintenance cover (right side), and fill the cap with cleaning solution as in step 7.
- 11** Close the gear cover.

4.3 Replacement of Consumable Item

To order replacement consumable items, contact your local dealer or our service office. For more information on consumable items, refer to our website (<https://mimaki.com/supply/inkjet.html>).



- Do not store consumable items in locations where children may enter.



- When disposing of consumable items, contact an industrial waste disposal operator or dispose of the product in accordance with the local laws and regulations.

Consumable Item Replacement Timing

Timing	Item
When dirty	"Replacing the Absorber Around the Station"(P. 111)
When ejection failures cannot be remedied	"Cap Replacement"(P. 109) "When Wiper End is Displayed"(P. 106)
When damaged	"Cap Replacement"(P. 109) "Media Holder Replacement"(P. 112) "Media Cutter Replacement"(P. 114)
When "Check Waste Ink Tank" appears on the display	"Waste Ink Tank Replacement"(P. 115)

Cloth Wiper Replacement

Replace cloth wipers with new ones when they have run out.

When Wiper Near End is Displayed

The remaining amount of cloth wiper is low. Cleaning is possible, but early replacement of the cloth wiper is recommended. Please note that if Auto Cleaning  "Maintenance Menu"(P. 83) is enabled, you can still print, but continuous printing and rewind printing will be interrupted.

When Wiper End is Displayed

We are unable to perform the cleaning because the cloth wiper is missing. Please note that if Auto Cleaning  "Maintenance Menu"(P. 83) is enabled, you will not be able to print. Please note that if the cloth wiper runs out during printing, continuous printing or rewind printing will be interrupted and cannot be resumed until the fabric wiper is replaced.



SPC-0919 and SPC-0932 cloth wipers

- Precautions are included with the cloth wipers. Thoroughly read them and make sure you understand the contents.
- When disposing of cloth wipers, **be sure to place them in a sealed bag**. Contact an industrial waste disposal operator or dispose of in accordance with the local laws and regulations.
- When handling cloth wipers, ensure adequate ventilation and take care not to inhale the solvent fumes.



- When handling SPC-0919 or SPC-0932 cloth wipers, be sure to wear safety glasses, gloves, and a mask. There is a risk of the liquid (solvent) contained in cloth wipers splashing and contacting your skin, eyes, or mouth.



- 1 "Wiper End" appears on the display.
- 2 On the LOCAL mode screen, select [MENU] > [Maintenance], then press the [ENTER] key.
 - The Maintenance menu is displayed.
- 3 Select [Station Maint.] > [Replace Wiper], then press the [ENTER] key.
 - The carriage moves over the platen.
- 4 Open the front cover.

5 Open the cloth wiper cover.

- Push the two tabs at the front up to open.

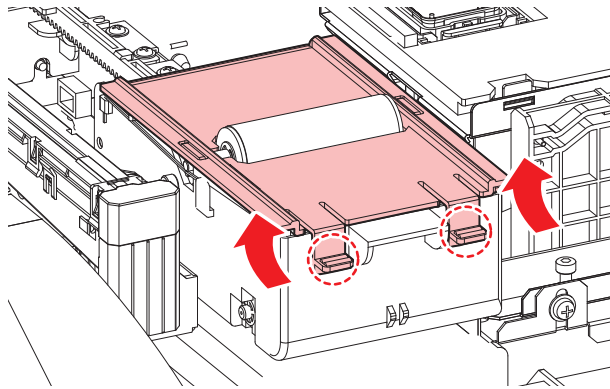

6 Remove the wiper together with the spindle.

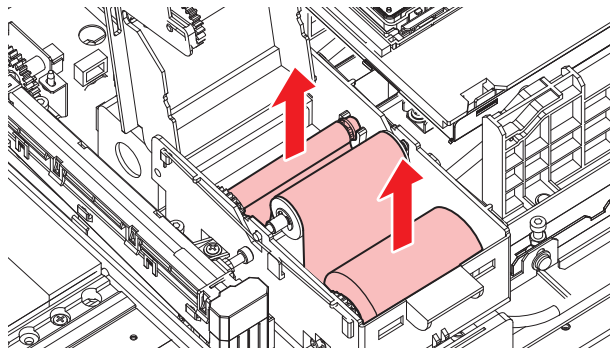

7 Remove the wiper from the spindle.



- When disposing of ink, maintenance liquid or other liquid used with the product, or containers or non-woven fabric contaminated with ink or other liquid, contact an industrial waste disposal operator or dispose of the product in accordance with the local laws and regulations.

8 Clean the wiper unit underside.

- Wipe off any ink and dust adhering using a cleaning stick moistened with maintenance liquid. Wipe off the maintenance liquid. Make sure none remains.

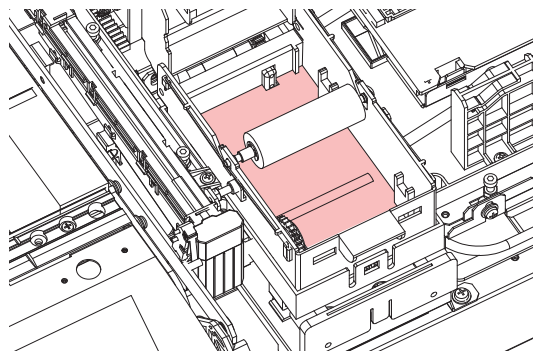

9 Clean the wipe roller.

- Wipe off any ink and dust adhering using a cleaning stick moistened with maintenance liquid. Wipe off the maintenance liquid. Make sure none remains.

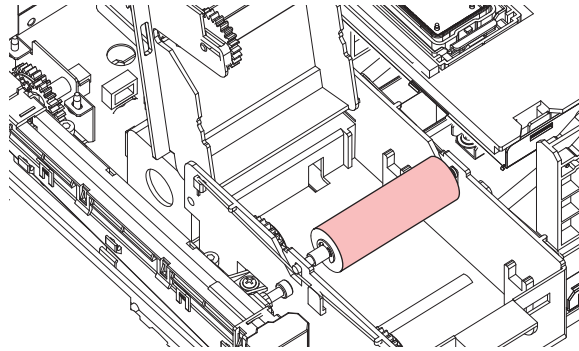

10 Clean the pinch rollers.

- Gently wipe off any dust adhering with a soft cloth.

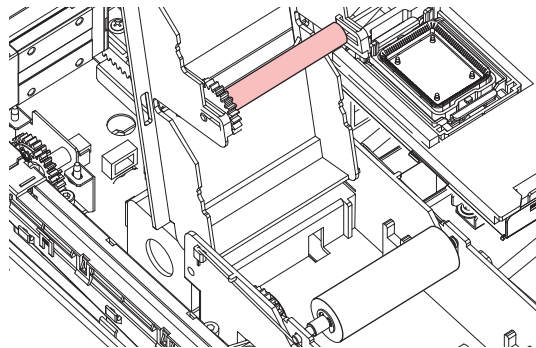

- Do not wipe too hard. Wiping too hard may degrade the sponge.
-

11 Mount a new cloth wiper.

- (1) Remove the cloth wiper from the bag.
- (2) Unroll the side with more cloth on it.

[When removed from bag]

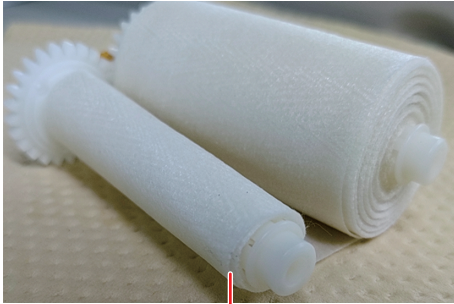

Wound approximately three times

[When mounted in the wiper unit]

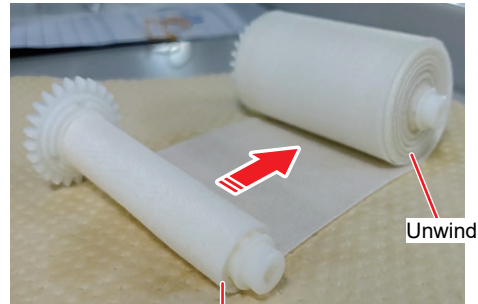

Do not unwind!

- (3) Mount a new cloth wiper.

- Mount the cloth wiper with the gear on the left.

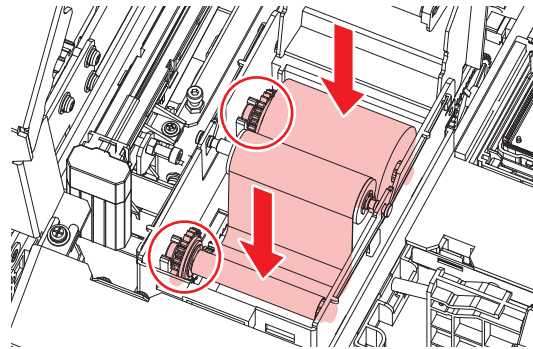

Important!

- If no cloth is wound around the spindle, wind the cloth around the spindle three times before mounting. If the cloth is mounted with no cloth wound around the spindle, the cloth may become detached from the wiper unit.

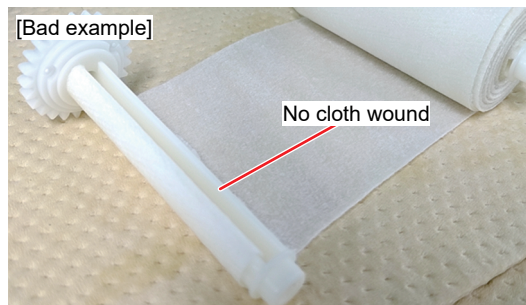

12 Close the cloth wiper cover.

13 Close the maintenance cover, then press the [ENTER] key.

- The remaining amount of cloth wiper is reset.

Cap Replacement

If ejection failures (e.g., nozzle clogging or deflection) remain unresolved even after cleaning, replace with a new cap.



- Be sure to replace the cap if you observe any scratches or other damage on the rim.

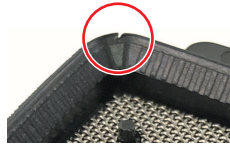

- We recommend replacing the cap every six to twelve months.

1 On the LOCAL mode screen, select [MENU] > [Maintenance], then press the [ENTER] key.

- The Maintenance menu is displayed.

2 Select [Station Maint.] > [Replace Cap], then press the [ENTER] key.

- The carriage moves over the platen.

3 Open the front cover.

4 Remove the cap.

- Squeeze the lugs on either side of the cap and pull off.

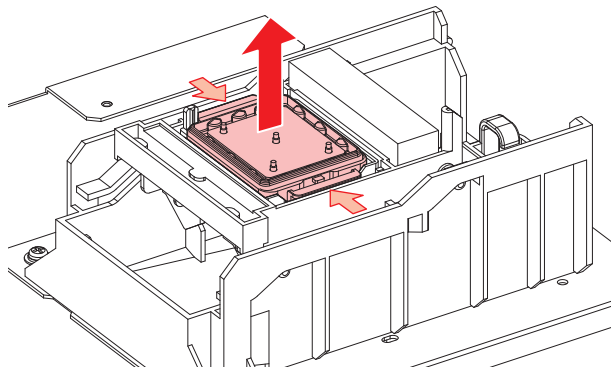

5 Apply maintenance liquid.

- Use a syringe to apply two or three drops of maintenance liquid to the hole at the front.

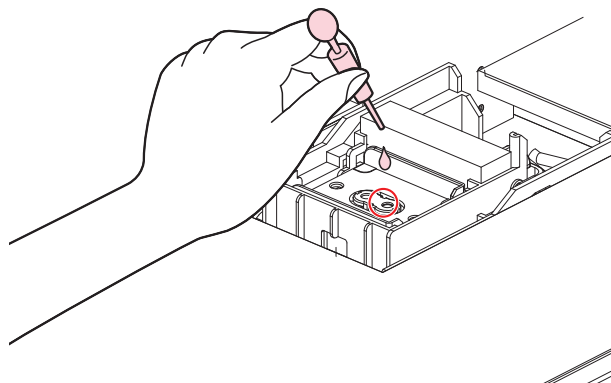

6 Mount a new cap.

- Position with the slot at the front and push in until it clicks.

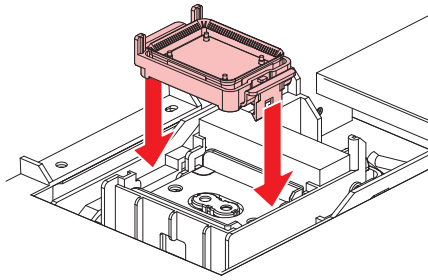

7 Once replacement is complete, close the cover, then press the [ENTER] key.

Replacing the Absorber Around the Station

If the cap absorber or maintenance liquid absorber is very dirty or if ink drips on to the media, replace with a new cap absorber.

- 1 On the LOCAL mode screen, select [MENU] > [Maintenance], then press the [ENTER] key.
 - The Maintenance menu is displayed.
- 2 Select [Station Maint.] > [Carriage Out] > [Move To Platen Right End], then press the [ENTER] key.
 - The carriage moves over the platen.
- 3 Open the front cover.
- 4 Remove the cap absorber.

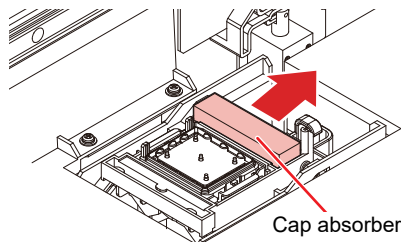

- Avoid ink dripping when removing the cap absorbers.

5 Clean the station cover.

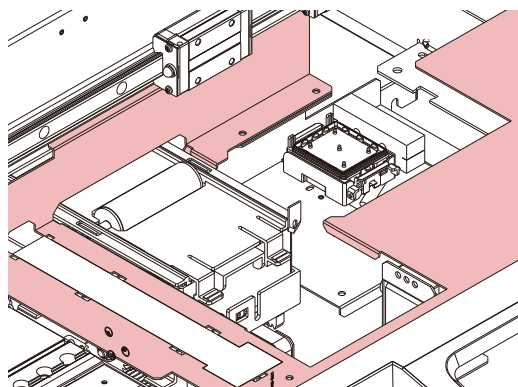

- For heavy soiling, wipe using a soft cloth soaked in diluted neutral detergent and thoroughly wrung out.

6 Mount a new cap absorber.



- Install the absorber so that the side with the narrower hole position faces upward and the side with the wider hole position faces downward, as shown in the figure.

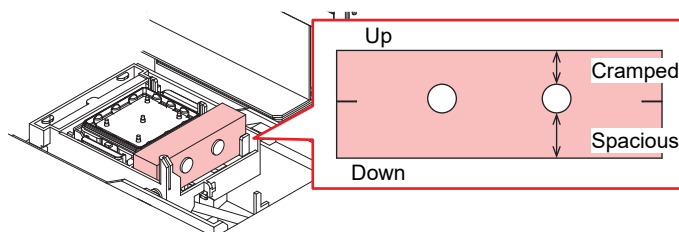

7 Once replacement is complete, close the cover, then press the [ENTER] key.

Media Holder Replacement

If the media holder becomes deformed and touches the carriage or print head, replace with a new media holder.



- Turn off the main power and unplug the power cable before replacement.

1 Open the maintenance cover (left side).

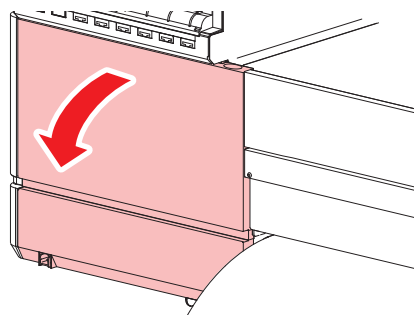

- 2** Remove the side screw, and detach the media holder stopper.

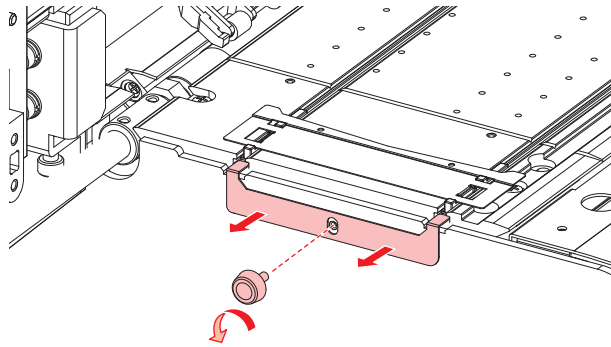

- 3** Remove the media holder.

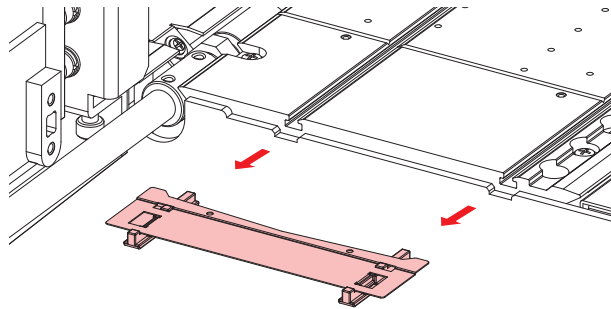

- 4** Mount the new media holder on to the platen.

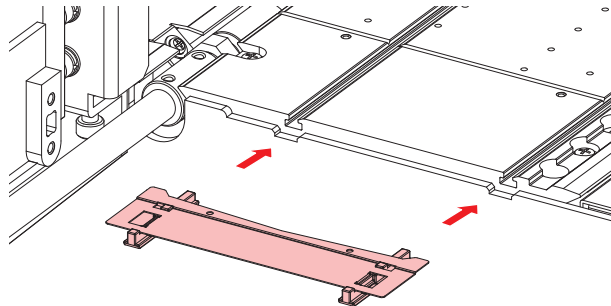

- 5** Secure the media holder stopper with the screw.

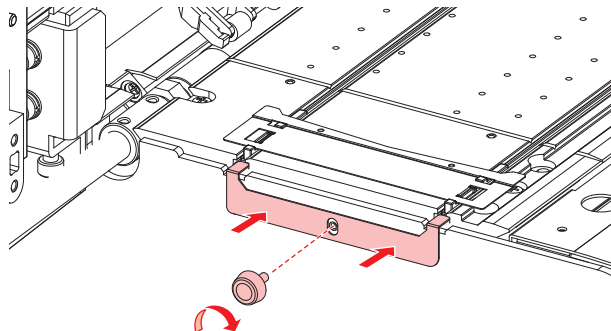

- 6** Close the maintenance covers.

Media Cutter Replacement

Replace cutters when blades are chipped or blunt.



- Avoid touching the cutter blade. Failure to do so may result in injury.

- 1 On the **LOCAL** mode screen, select **[MENU] > [Maintenance]**, then press the **[ENTER]** key.
 - The Maintenance menu is displayed.
- 2 Select **[Station Maint.] > [Carriage Out] > [Move To Platen Right End]**, then press the **[ENTER]** key.
 - The carriage moves over the platen.



- The carriage can be moved by hand. Move the carriage slowly to a position allowing easy access while working.

- 3 Open the front cover.

- 4 Replace the media cutter.
 - (1) Unscrew the cutter screw.

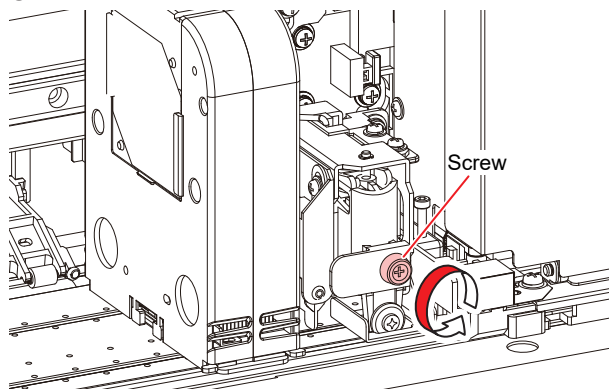

- (2) Remove the cutter.

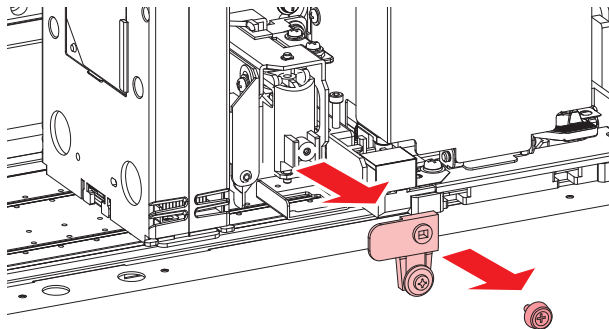

- (3) Mount a new cutter.
- (4) Tighten the screw to clamp the cutter.

5 Check the position of the media cutter.

- Lift up the media cutter by hand if it has dropped down.

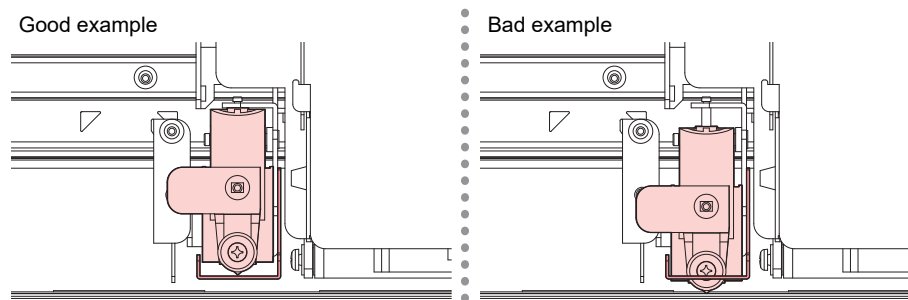

6 Once replacement is complete, press the [ENTER] key.

Waste Ink Tank Replacement

Ink used during head cleaning and other processes is collected in the waste ink tank at the lower right of the machine.

This product keeps track of the waste ink level. A "Check Waste Ink Tank" message appears when the preset level is reached. Use this a guide for replacing the waste ink tank.





- For a 2-liter tank, the preset level is 80 % (1.6 L).
- Continuing to use the product without disposing of the waste ink may result in waste ink overflowing from the waste ink tank. Visually check ink levels in the waste ink tank about once a week.



- Pay close attention to ventilation and be sure to wear safety glasses, gloves, and a mask when handling ink, maintenance liquid, waste ink, or other solutions used with the machine. Leaking ink may adhere to the skin or get into the eyes or mouth.



When "Check Waste Ink Tank" message appears

- 1 The "Check Waste Ink Tank" message appears on the display.
- 2 Check the waste ink levels in the waste ink tank.
 - If you note any discrepancies from actual levels, proceed to the next step.
 - If there is no discrepancy, replace (dispose of) the waste ink tank referring to  ["Replacing the Waste Ink Tank"\(P. 116\)](#).
- 3 On the LOCAL mode screen, select [MENU] > [Maintenance], then press the [ENTER] key.
 - The Maintenance menu is displayed.
- 4 Select [Waste Ink Tank], then press the [ENTER] key.
- 5 Select [Adjust Waste Ink Volume], then press the [ENTER] key.
- 6 Press   to adjust the level.

- 7 Press the [ENTER] key once adjustment is complete.

Replacing the Waste Ink Tank

- 1 On the LOCAL mode screen, select [MENU] > [Maintenance], then press the [ENTER] key.
 - The Maintenance menu is displayed.
- 2 Select [Waste Ink Tank], then press the [ENTER] key.
- 3 Select [Reset Waste Ink Volume], then press the [ENTER] key.
- 4 Pull the waste ink tank stopper forward.

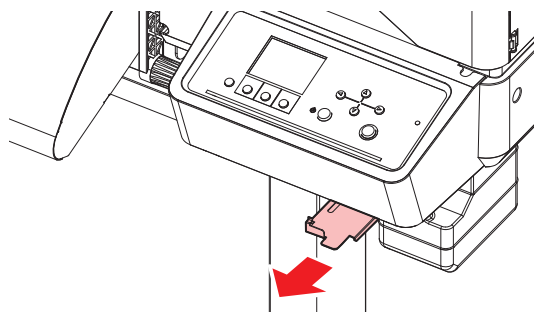

- 5 Hold the handle on the waste ink tank and slide out.

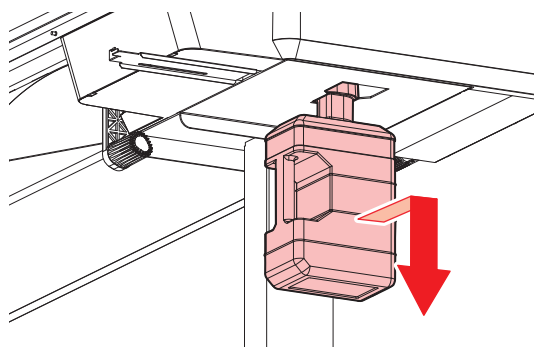

- 6 Attach the cap to the removed waste ink tank, and use tape to prevent leakage of waste ink.

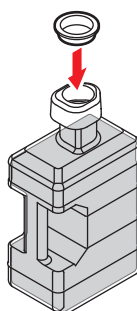

- When disposing of ink, maintenance liquid or other liquid used with the product, or containers or non-woven fabric contaminated with ink or other liquid, contact an industrial waste disposal operator or dispose of the product in accordance with the local laws and regulations.
-

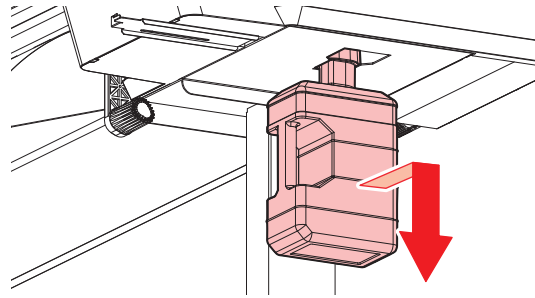
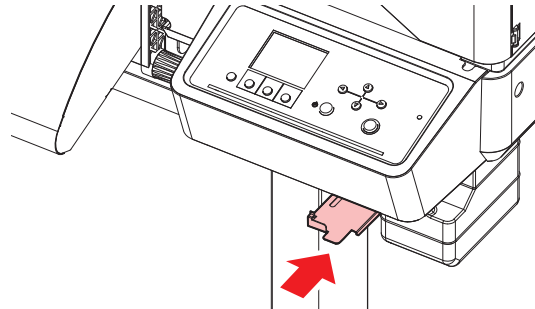
7 Mount a new waste ink tank.**8** Close the waste ink tank stopper.**9** Press the [ENTER] key.

- The waste ink level will be reset.

Ink bottle cap replacement

Replace them after about one year. For the replacement method, refer to Replacing Ink.



- Pay close attention to ventilation and be sure to wear safety glasses, gloves, and a mask when handling ink, maintenance liquid, waste ink, or other solutions used with the machine. Leaking ink may adhere to the skin or get into the eyes or mouth.



Chapter 5 Troubleshooting



This chapter

This chapter describes corrective actions for troubleshooting and messages on the display.





Troubleshooting.....	120	The light-blocking cover comes off.	125
The power does not turn on.	120	Abnormal noise occurs during cleaning	126
Printing is not possible.	120	Problems Causing Messages to Appear	127
The media jams or the media is dirty.	120	Warning Messages	127
Image defects occur.....	121	Ink error.....	130
The heater temperature does not rise to the specified value.	125	Error Message	131
The ink has leaked out.....	125	SYSTEM HALT	138

5.1 Troubleshooting





For information on troubleshooting, refer to this chapter. Refer to our website (<https://mimaki.com/support/>) for frequently asked questions (FAQs) about this product and customer support videos.

If the recommended corrective action does not resolve the problem, contact your local dealer or our service office.

The power does not turn on.

Points to check	Corrective action
Is the machine connected to the power outlet by the power cable?	Connect the power plug securely to the power outlet.  "Connecting the Power Cable"(P. 32)
Are you using the power cable provided?	Use the power cable provided.
Is the main power supply turned on?	Turn on the main power supply.   "Turning On the Power"(P. 32)
Is the [END/POWER] key on the operating panel turned on?	Turn the power on.  "Turning On the Power"(P. 32)

Printing is not possible.

Points to check	Corrective action
Is a USB interface cable connected?	Connect the cable securely to the USB 2.0 port.  "Using a USB Cable"(P. 36)
Is a LAN cable connected?	Connect the cable securely to the LAN port.  "Using a LAN Cable"(P. 35)
Are you using a LAN cable approved by Mimaki?	Check the LAN cable type.  "Using a LAN Cable"(P. 35)
Is the status lamp on the operating panel illuminated or flashing red?	An error has occurred. Check the message on the display.  "Operating Panel"(P. 29)

The media jams or the media is dirty.

Points to check	Corrective action
Are you using the recommended media?	Make sure you are using the recommended media. https://mimaki.com/supply/inkjet.html
Are you using curled media?	Do not use curled media or media with folded ends.
Is the media skewed?	Use the take-up unit to adjust the media or reload the media.  "Loading the Media"(P. 52)

Points to check	Corrective action
Does the media have ripples/surface irregularities or lift up?	<p>If you are using roll media, use a smooth section of the media for initial feeding. You can also improve this problem by attaching the NITOFロン[®] tape provided on the platen.</p>  <p>Be careful not to cover the vacuum holes.</p> <p>For more information, refer to the description on transporting media on the platen. https://mimaki.com/download/inkjet.html</p>

Image defects occur.

Symptom	Corrective action
White streaks, blurriness, and dark streaks ^{*1} occur. (Carriage scan direction)	<ol style="list-style-type: none"> 1. Remove any paper scraps or other debris adhering to areas over which the head passes (e.g., media holders). (☞ "Media Holder Cleaning"(P. 101)☞ "Platen Cleaning"(P. 102) 2. Perform the procedure described in (☞ "Head Cleaning"(P. 67). 3. Perform the procedure described in (☞ "Feed Correction"(P. 69). 4. Perform the procedure described in (☞ "Cap Rubber Cleaning"(P. 94). 5. Perform the procedure described in (☞ "Carriage Underside Cleaning"(P. 95).
Text is double- or triple-printed in the media feed direction.	<ol style="list-style-type: none"> 1. Perform the procedure described in (☞ "Feed Correction"(P. 69).
Offsetting occurs during bidirectional printing.	<ol style="list-style-type: none"> 1. Perform the procedure described in (☞ "Correcting the Drop Position"(P. 71).
Ink droplets drip during printing.	<ol style="list-style-type: none"> 1. Perform the procedure described in (☞ "Cap Rubber Cleaning"(P. 94). 2. Perform the procedure described in (☞ "Carriage Underside Cleaning"(P. 95). 3. Perform the procedure described in (☞ "Head Cleaning"(P. 67). 4. Set auto maintenance. (☞ "Maintenance Menu"(P. 83)
Nozzles are clogged.	<ol style="list-style-type: none"> 1. Perform the procedure described in (☞ "Head Cleaning"(P. 67). 2. Perform the procedure described in (☞ "Print Head Nozzle Washing"(P. 123). 3. Perform the procedure described in (☞ "Registering Nozzle Recovery Manually"(P. 86).
Are the print heads too high?	<p>Adjust the print head height. (☞ "Adjusting Print Head Height"(P. 51)</p> <p>If the print heads cannot be lowered, increase the refresh level during printing (☞ P. 83) or perform regular test printing to check for nozzle clogging.</p>
Are there any ink colors that aren't used much?	<p>Discharge from infrequently used nozzles tends not to be consistent. Although increasing the refresh level during printing (☞ P. 83) will enable more frequent nozzle use, note that this will also increase ink consumption.</p>
Are you using media easily affected by static electricity?	<p>Increase the refresh level during printing (☞ P. 83) or perform regular test printing to check for nozzle clogging.</p>

Symptom	Corrective action
Is the machine installed in a location with low humidity?	Increase the humidity by installing a humidifier or similar equipment. When printing continuously, also increase the refresh level during printing (🔗 P. 83) or perform regular test printing to check for nozzle clogging.
Is the machine installed in a location where dust or powder is present?	Install the machine in a location free of dust or powder (office equivalent: dust level 0.15 mg/m ³).

*1. Even if test printing is OK, horizontal streaks may appear on the solid color print when the resolution is set to 900 × 600dpi and the scan speed is set to "Hi".

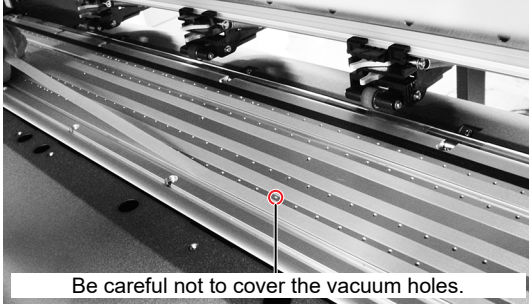
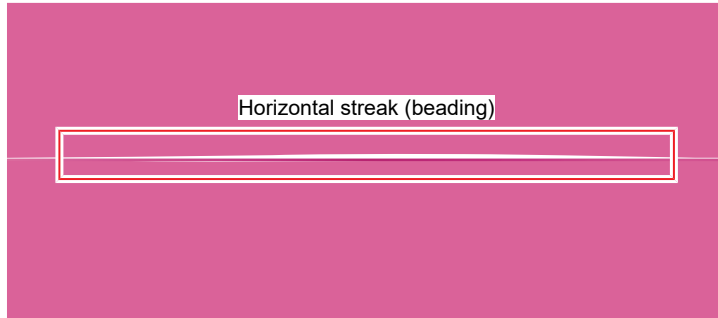

If horizontal streaks reappear even after the corrective actions in the table are taken, check the following settings and change the print conditions.

- Use the profile suitable for the media.
- Increase the heater temperature. (🔗 "Setting the Heater Temperature"(P. 64))
- Increase the number of passes.

Print Head Nozzle Washing

If ejection failures (e.g., nozzle clogging or deflection) remain unresolved even after head cleaning (Head Cleaning), apply nozzle wash to the print head.

- 1** On the LOCAL mode screen, select [MENU] > [Maintenance], then press the [ENTER] key.
 - The Maintenance menu is displayed.
- 2** Select [Station Maint.] > [Nozzle Wash], then press the [ENTER] key.
 - The carriage moves over the platen.
- 3** Open the front cover.
 - Wiper Cleaning
- 4** Clean the cap rubber.
 -  ["Cap Rubber Cleaning"\(P. 94\)](#)
- 5** Fill the cap with maintenance liquid.



- Use a syringe to draw up some maintenance liquid and fill until it almost overflows from the cap.

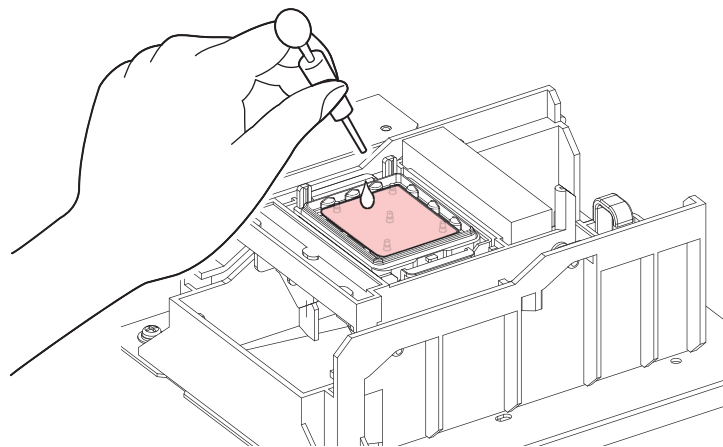

- 6** Close the gear cover.
- 7** Press the [ENTER] key.
 - Cleaning is performed automatically once print nozzle washing has ended.



- If ejection failures (e.g., nozzle clogging or deflection) remain unresolved even after washing the nozzles several times, contact your local dealer or our service office.

There is considerable nozzle clogging with white ink

If there is considerable nozzle clogging with white ink (dropouts), perform Air PG. Note that this consumes a large amount of ink.

1 On the LOCAL mode screen, select [MENU] > [Maintenance], then press the [ENTER] key.

- The Maintenance menu is displayed.

2 Select [Air PG], then press the [ENTER] key.

3 Press , then select [YES].

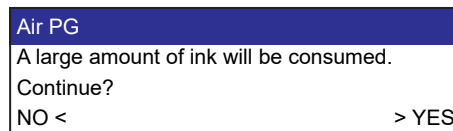

4 Press , then select [YES].

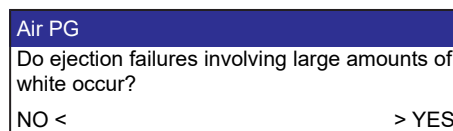

5 The "Check Waste Ink Tank" message appears on the display.

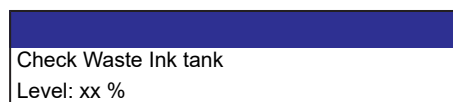

6 Check the waste ink levels in the waste ink tank.

- If there are discrepancies from actual levels, correct the waste ink amount. When "Check Waste Ink Tank" message appears
- If there is no discrepancy, replace (dispose of) the waste ink tank referring to Replacing the Waste Ink Tank.

7 Press the [ENTER] key to start air purging.





8 Perform a test print and check the print results.

- Test Printing

The heater temperature does not rise to the specified value.

This may indicate a problem with the setting.

Points to check	Corrective action
Is the heater temperature set?	Set the heater temperature.  "Setting the Heater Temperature"(P. 64)  "Media Setting Menu"(P. 80)
Is the 100V/200V selector switch set correctly?	You need to check the power switch. Contact your local dealer or our service office.

The ink has leaked out



- If an ink leak occurs, turn off the main power immediately and unplug the power cable. Then, contact your local dealer or our service office.

The light-blocking cover comes off.

If the light-blocking cover is left off, the ink inside the ink supply unit may be exposed to light and begin to harden.

If the light-blocking cover comes loose, reattach as follows:

- 1** Insert the lug on one side of the light-blocking cover into the corresponding hole in the tank.

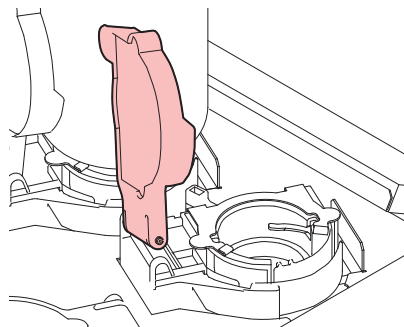

- 2** Insert the lug on the other side while pushing in toward the first hole in Step 1.

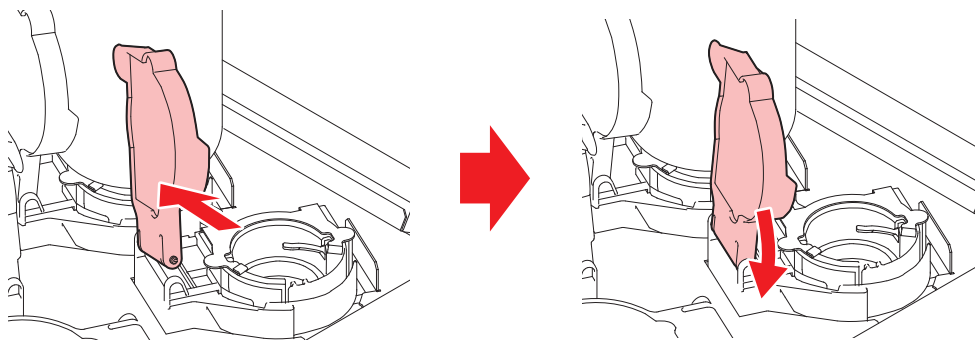

Abnormal noise occurs during cleaning

Cloth wiper may be entangled in the cloth wiper gear. Remove the cloth wiper and replace it.

Important!

- Perform the following procedure: Use the [Replace Wiper] menu to reset the wiper remaining amount.



- When handling **SPC-0919 or SPC-0932 cloth wipers**, be sure to wear safety glasses, gloves, and a mask. There is a risk of the liquid (solvent) contained in cloth wipers splashing and contacting your skin, eyes, or mouth.



- 1 On the LOCAL mode screen, select [MENU] > [Maintenance], then press the [ENTER] key.
 - The Maintenance menu is displayed.
- 2 Select [Station Maint.] > [Carriage Out] > [Move To Platen Right End], then press the [ENTER] key.
 - The carriage moves over the platen.
- 3 Open the front cover.
- 4 Open the cloth wiper cover.
 - Push the two tabs at the front up to open.

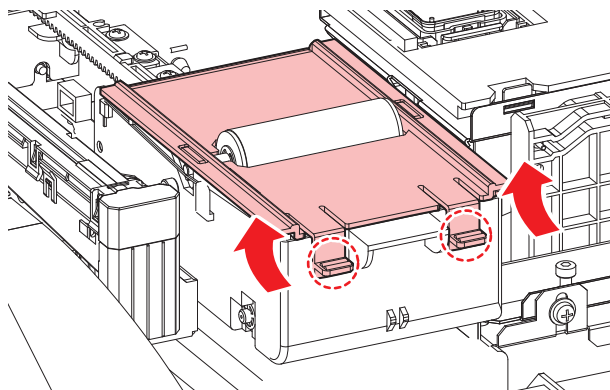

- 5 Remove the cloth wiper together with the spindle, then replace it.

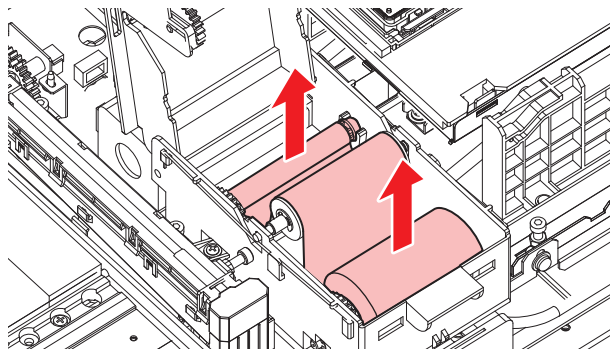









5.2 Problems Causing Messages to Appear

If a problem arises, the buzzer sounds and a message appears on the display.

You can also check the local guidance.  ["Displaying Machine Information \(Local Guidance\)"\(P. 31\)](#)

Take the appropriate action in accordance with the content of the message. If a message reappears even after taking the prescribed action, contact your local dealer or our service office.

Warning Messages











Message	Cause	Corrective action
Replace NCU ^{*1} Ink Pad	<ul style="list-style-type: none"> The ink absorber needs to be replaced. 	<ul style="list-style-type: none"> The NCU^{*1} ink absorber must be replaced. Contact your local dealer or our service office.
Replace NCU ^{*1}	<ul style="list-style-type: none"> A problem was detected with the nozzle clogging assessment. 	<ul style="list-style-type: none"> Clean the NCU^{*1}.  "NCU (Option) Cleaning"(P. 97) Replace the NCU^{*1} if the error is not cleared. Contact your local dealer or our service office.
NCU ^{*1} Sensor Lv Low	<ul style="list-style-type: none"> The sensor's sensitivity is impaired. 	<ul style="list-style-type: none"> Clean the NCU^{*1}.  "NCU (Option) Cleaning"(P. 97)
NCU ^{*1} Sens Adj Err H	<ul style="list-style-type: none"> Sensor sensitivity adjustment failed. 	<ul style="list-style-type: none"> Replace the NCU^{*1} if the error is not cleared. Contact your local dealer or our service office.
NCU ^{*1} Sens Adj Err L		
NCU ^{*1} Connect	<ul style="list-style-type: none"> A problem was detected with the NCU^{*1} connection. 	<ul style="list-style-type: none"> Turn off the main power and wait a while before turning back on.
Ink Error	<ul style="list-style-type: none"> An ink error occurred. 	<ul style="list-style-type: none"> Check the ink error details.  "Ink error"(P. 130)
COVER OPEN	<ul style="list-style-type: none"> The cover is open. 	<ul style="list-style-type: none"> Close the cover.
Lower the clamp lever	<ul style="list-style-type: none"> The clamp lever is raised. 	<ul style="list-style-type: none"> Lower the clamp lever.  "Front"(P. 24)
Data Remain	<ul style="list-style-type: none"> Print (RIP) data was received. 	<ul style="list-style-type: none"> Switch to REMOTE mode and start printing or clear the data and abort printing.
Temporary Suspension	<ul style="list-style-type: none"> Printing has been paused. 	<ul style="list-style-type: none"> Switch to REMOTE mode and resume printing or clear the data and abort printing.
Printing not possible/ink IC	<ul style="list-style-type: none"> An unusable ink IC chip is used. 	<ul style="list-style-type: none"> Replace with new ink and a new ink IC chip.  "Replacing Ink"(P. 41)
No Media	<ul style="list-style-type: none"> No media is loaded, or the sensors are faulty. 	<ul style="list-style-type: none"> Load the media.  "Loading the Media"(P. 52) Clean the media sensor.  "Media Sensor Cleaning"(P. 99)
Please load media	<ul style="list-style-type: none"> No media is loaded, or the sensors are faulty. 	<ul style="list-style-type: none"> Load the media.  "Loading the Media"(P. 52)

Message	Cause	Corrective action
Media Undetected	<ul style="list-style-type: none"> The media width has not been detected. 	<ul style="list-style-type: none"> Detect the media width. "Loading the Media"(P. 52)
Wiper Move Failure	<ul style="list-style-type: none"> The wiper is not operating correctly. 	<ul style="list-style-type: none"> Turn off the main power and wait a while before turning back on.
Replace Wasteinktank	<ul style="list-style-type: none"> The waste ink tank count exceeded the preset value (90%). 	<p>Automatic maintenance is not possible while the covers are open. Perform the following steps:</p> <ol style="list-style-type: none"> Check the waste ink levels in the waste ink tank. "When "Check Waste Ink Tank" message appears"(P. 115) Replace the waste ink tank, then reset the waste ink level. "Replacing the Waste Ink Tank"(P. 116)
Check Waste Ink tank	<ul style="list-style-type: none"> The waste ink tank count exceeded the preset value (80%). 	<ol style="list-style-type: none"> Check the waste ink levels in the waste ink tank. "When "Check Waste Ink Tank" message appears"(P. 115) Replace the waste ink tank, then reset the waste ink level. "Replacing the Waste Ink Tank"(P. 116)
High ambient temp ** ° C	<ul style="list-style-type: none"> Ambient temperatures are too high. 	<ul style="list-style-type: none"> Adjust ambient temperatures to temperatures within the specified range. Optimum print quality may not be possible unless ambient conditions are within the specified range. "Installation Precautions"(P. 16)
Low ambient temp ** ° C	<ul style="list-style-type: none"> Ambient temperatures are too low. 	
Auto Correction Error	<ul style="list-style-type: none"> The media is dirty. The media lifts up. There is dirt around the sensor. 	<ul style="list-style-type: none"> Load white and clean media. Load media so it does not lift up. Clean the area around the sensor. "DAS (automatic correction function) / Sheet width sensor cleaning"(P. 98) Replace the NCU if the error does not clear. Contact your local dealer or our service office.
Color sensor light intensity shortage	<ul style="list-style-type: none"> The underlying surface is not drawn when colored or transparent media is used. The media is dirty. The media lifts up. There is dirt around the sensor. 	<ul style="list-style-type: none"> If colored/transparent media is used, please draw a base layer. "Auto Correction"(P. 68) Load white and clean media. Load media so it does not lift up. Clean the area around the sensor. "DAS (automatic correction function) / Sheet width sensor cleaning"(P. 98) Replace the NCU if the error does not clear. Contact your local dealer or our service office.
Media detection failure	<ul style="list-style-type: none"> The media holder is not properly set. The platen is dirty. There is printed material or dirt on the media on the platen. There is dirt around the sensor. 	<ul style="list-style-type: none"> Use the media holder when detecting media. "Loading the Roll Media"(P. 57) Clean the platen. "Platen Cleaning"(P. 102) Please feed the media to a position free of printed material or smudges, ensuring there



Message	Cause	Corrective action
		<ul style="list-style-type: none">• Clean the area around the sensor.  "DAS (automatic correction function) / Sheet width sensor cleaning"(P. 98)• Replace the NCU if the error does not clear. Contact your local dealer or our service office.

*1 NCU is optional.

Ink error

Message	Cause	Corrective action
Ink End	<ul style="list-style-type: none"> The ink has run out. 	<ul style="list-style-type: none"> Replace with new ink.  "When Ink End is Displayed"(P. 40)
Ink Near End	<ul style="list-style-type: none"> Ink levels are low. 	<ul style="list-style-type: none"> The ink will run out soon. Have new ink ready.  "When Ink Near End is Displayed"(P. 40)
Non Ink IC	<ul style="list-style-type: none"> No ink IC chip was detected. 	<ol style="list-style-type: none"> Insert the ink IC chip.  "Replacing Ink"(P. 41) Check to confirm the ink IC chip was inserted correctly.  "Replacing Ink"(P. 41) Turn off the main power and wait a while before turning back on.
Wrong Ink IC	<ul style="list-style-type: none"> An error occurred with the information on the ink IC chip. 	<ol style="list-style-type: none"> Check to confirm the ink IC chip was inserted correctly.  "Replacing Ink"(P. 41) Turn off the main power and wait a while before turning back on. Replace with new ink.  "Replacing Ink"(P. 41)
Ink Color	<ul style="list-style-type: none"> The ink color registered on the IC chip is different from the ink color filled. 	<ul style="list-style-type: none"> Insert an ink IC chip for the correct ink color.  "Replacing Ink"(P. 41)
Ink Type	<ul style="list-style-type: none"> The ink type registered on the IC chip is different from the ink type filled. 	<ul style="list-style-type: none"> Insert an ink IC chip for the correct ink type.  "Replacing Ink"(P. 41)
Expiration Near	<ul style="list-style-type: none"> The ink has expired. 	<ul style="list-style-type: none"> Replace with new ink or use up as quickly as possible. Printing is possible.  "When Ink End is Displayed"(P. 40)
Expiration Over	<ul style="list-style-type: none"> The ink is two months past its expiration date and cannot be used. 	<ul style="list-style-type: none"> Replace with new ink. Printing is not possible.  "When Ink End is Displayed"(P. 40)
Excess Ink Usage	<ul style="list-style-type: none"> The amount of ink used exceeded the specified value. 	<ul style="list-style-type: none"> Replace with new ink.  "When Ink End is Displayed"(P. 40) Check to confirm the nozzle is not clogged.

Error Message





Error number	Message	Cause	Corrective action
04	PARAM ROM	<ul style="list-style-type: none"> A problem was detected with the main PCB. 	<ul style="list-style-type: none"> Turn off the main power and wait a while before turning back on.  "Turning Off the Power"(P. 33)
108	HD THERMIS[1]	<ul style="list-style-type: none"> A problem was detected with print head temperature control. 	
108	HD CONNECT[1]	<ul style="list-style-type: none"> A problem was detected with the print head connection. 	
108	HD MEM EMP[1]	<ul style="list-style-type: none"> A problem was detected with the print head. 	
10e	FROM CLEAR	<ul style="list-style-type: none"> A problem was detected with the main PCB. 	
10f	FROM WRITE		
122	CHECK:SDRAM	<ul style="list-style-type: none"> A problem was detected with the SDRAM. 	
123	PRAM DATA	<ul style="list-style-type: none"> A problem was detected with the main PCB. 	
124	PRAM ADDR		
127	POWER OFF		
128	HDC FIFO OVER	<ul style="list-style-type: none"> A problem was detected with the print head control PCB. 	
128	HDC FIFO UNDER		
129	Battery Exchange	<ul style="list-style-type: none"> The internal clock battery is spent and must be replaced. 	<ul style="list-style-type: none"> Contact your local dealer or our service office.
12a	HDC SPEED	<ul style="list-style-type: none"> A problem was detected with the print head control. 	<ul style="list-style-type: none"> Turn off the main power and wait a while before turning back on.  "Turning Off the Power"(P. 33)
130	HD DATA SEQ	<ul style="list-style-type: none"> A problem was detected with the print head control. 	
147	DS-IC BUSY	<ul style="list-style-type: none"> Ink IC control abnormality detected. 	
148	E-LOG SEQ	<ul style="list-style-type: none"> A log control abnormality was detected. 	
154	Main PCB V05	<ul style="list-style-type: none"> A problem was detected with the main PCB 5V power supply. 	
155	Main PCB V42-1	<ul style="list-style-type: none"> A problem was detected with the main PCB 42V power supply. 	
15f	HEAD DRIVE HOT	<ul style="list-style-type: none"> A new print head connection was detected. 	
171	NEW HEAD CONNECT		
186	HDC OVERFLOW/HDC UNDERFLOW	<ul style="list-style-type: none"> A problem was detected with the print head control. 	
187	HDC SLEW RATE		
188	HDC MEMORY		



Error number	Message	Cause	Corrective action
18e	FLS NOT COMP	<ul style="list-style-type: none"> A problem was detected with the print head control. 	
18f	OFFSET START [1]		
18f	OFFSET END [1]		
1b8	HEAD XHOT	<ul style="list-style-type: none"> A problem was detected with the print head. 	
201	Command Error	<ul style="list-style-type: none"> Data other than print (RIP) data was received, or a problem was detected with the print (RIP) data received. 	<ol style="list-style-type: none"> Clear the data and resend. Check the USB/Ether cable connection. "Displaying Machine Information (Local Guidance)"(P. 31) Use a compatible cable. "Displaying Machine Information (Local Guidance)"(P. 31) Turn off the main power and wait a while before turning back on.
202	Parameter Error	<ul style="list-style-type: none"> A problem was detected with the print (RIP) data received. 	
206	Print Mode Error	<ul style="list-style-type: none"> Print (RIP) data was received with print parameters that do not allow printing. 	<ul style="list-style-type: none"> Change the output parameters and profile using RIP software.
20a	Driver Version	<ul style="list-style-type: none"> Printing is not possible because the Mimaki driver version is old. 	<ul style="list-style-type: none"> Install the latest Mimaki driver available from: https://mimaki.com/download/inkjet.html
303	PCB MAIN ET	<ul style="list-style-type: none"> A problem was detected with the main PCB. 	<ol style="list-style-type: none"> Turn off the main power and wait a while before turning back on. "Turning Off the Power"(P. 33)
304	USB INIT ERR	<ul style="list-style-type: none"> A problem was detected with the USB cable connection. 	<ol style="list-style-type: none"> Check the USB cable connection. "Using a USB Cable"(P. 36) Use a compatible cable. "Using a USB Cable"(P. 36) Turn off the main power and wait a while before turning back on. "Turning Off the Power"(P. 33)
305	USB TIME OUT		
401	Motor X	<ul style="list-style-type: none"> The X motor was overloaded. 	<ol style="list-style-type: none"> Check to confirm the media is loaded correctly. "Loading the Media"(P. 52) Check for anything that may obstruct carriage movement. Turn off the main power and wait a while before turning back on. "Turning Off the Power"(P. 33)
402	Motor Y	<ul style="list-style-type: none"> The Y motor was overloaded. 	
403	X Current	<ul style="list-style-type: none"> An overcurrent error was detected in the X motor. 	
404	Y Current	<ul style="list-style-type: none"> An overcurrent error was detected in the Y motor. 	
406	Wiper Move Failure	<ul style="list-style-type: none"> The wiper origin could not be detected. 	<ul style="list-style-type: none"> Turn off the main power and wait a while before turning back on. "Turning Off the Power"(P. 33)
44f	Take-up Roll Sns Err	<ul style="list-style-type: none"> A problem was detected with the take-up unit sensor spindle. 	<ol style="list-style-type: none"> Check to confirm the [Function Setting] > [Take-up Unit] setting is "ON". Check to confirm the media is loaded correctly. "Loading the Roll Media"(P. 57) Check to confirm the take-up unit switch functions properly. "Take-up unit"(P. 53)

Error number	Message	Cause	Corrective action
47f	Take-up Diameter Max	<ul style="list-style-type: none"> The take-up unit media diameter has reached the maximum value. 	<ol style="list-style-type: none"> Replace the paper core in the take-up unit.
504	CLAMP UP	<ul style="list-style-type: none"> The clamp lever is lifted. 	<ul style="list-style-type: none"> Lower the clamp lever.
505	Media Jam	<ul style="list-style-type: none"> The media jam sensor was triggered. 	<ol style="list-style-type: none"> Remove the media in contact with the carriage and reload with fresh media. ☞ "Loading the Media"(P. 52) Check for anything that may obstruct carriage movement.
509	HDC POSCNT	<ul style="list-style-type: none"> A problem was detected with position control. 	<ul style="list-style-type: none"> Turn off the main power and wait a while before turning back on. ☞ "Turning Off the Power"(P. 33)
50a	Y Org Detect Error	<ul style="list-style-type: none"> A problem was detected with Y origin detection (initialization). 	
50c	Check Media With Sensor	<ul style="list-style-type: none"> A problem was detected with media width detection. 	<ol style="list-style-type: none"> Check the media loading position. ☞ "Loading the Media"(P. 52) Clean the media width sensor. ☞ "DAS (automatic correction function) / Sheet width sensor cleaning"(P. 98)
50f	L-SCALE BLACK	<ul style="list-style-type: none"> A problem was detected with the linear scale. 	<ul style="list-style-type: none"> Turn off the main power and wait a while before turning back on. ☞ "Turning Off the Power"(P. 33)
516	Media Set Position R (L)	<ul style="list-style-type: none"> The media was loaded outside the range of valid positions. 	<ol style="list-style-type: none"> Check the media loading position. ☞ "Loading the Media"(P. 52) Clean the media width sensor. ☞ "Media Sensor Cleaning"(P. 99)
525	Wrong Ionizer	<ul style="list-style-type: none"> The ionizer internal circuit is defective, or an abnormal discharge occurred. 	<ul style="list-style-type: none"> Turn off the main power and wait a while before turning back on. ☞ "Turning Off the Power"(P. 33)
526	Ionizer Ion Level	<ul style="list-style-type: none"> The amount of generated ions was reduced by fouling and abrasion of the electrode needle. 	<ul style="list-style-type: none"> Refer to the instruction manual for the ionizer and clean the electrodes.
527	Ionizer Condition	<ul style="list-style-type: none"> Ambient conditions may cause ions to be absorbed by metals in the vicinity and affect discharge capability. 	<ul style="list-style-type: none"> Remove any conductors or discharge devices close to the ionizer.
54b	Media Press	<ul style="list-style-type: none"> Media retainer detection failed. 	<ol style="list-style-type: none"> Check the media loading position. ☞ "Loading the Media"(P. 52) Clean the media width sensor. ☞ "Media Sensor Cleaning"(P. 99)
54c	Vacuum Fan Err	<ul style="list-style-type: none"> A problem was detected with the vacuum fan. 	<ul style="list-style-type: none"> Turn off the main power and wait a while before turning back on. ☞ "Turning Off the Power"(P. 33)
54e	UV-LED Fan Err	<ul style="list-style-type: none"> A UV-LED cooling fan rotation abnormality was detected. 	

Error number	Message	Cause	Corrective action
602	Ink End	<ul style="list-style-type: none"> The ink has run out. 	<ul style="list-style-type: none"> Replace with new ink. "When Ink End is Displayed"(P. 40)
604	Check Waste Ink tank	<ul style="list-style-type: none"> The waste ink tank count exceeded the preset value (80%). 	<ol style="list-style-type: none"> Check the waste ink levels in the waste ink tank. "When "Check Waste Ink Tank" message appears"(P. 115) Replace the waste ink tank, then reset the waste ink level. "Replacing the Waste Ink Tank"(P. 116)
608	Wrong Ink IC	<ul style="list-style-type: none"> An error occurred with the information on the ink IC chip. 	<ol style="list-style-type: none"> Check to confirm the ink IC chip was inserted correctly. "Replacing Ink"(P. 41) Turn off the main power and wait a while before turning back on. "Turning Off the Power"(P. 33) Replace with new ink. "Replacing Ink"(P. 41)
60a	Excess Ink Usage	<ul style="list-style-type: none"> The ink usage amount stored in the ink IC chip exceeded the preset value. The ink IC chip was not replaced during ink replacement. (The same chip continued to be used.) The machine was used with nozzle clogging. 	<ul style="list-style-type: none"> Replace with new ink. "When Ink End is Displayed"(P. 40)
60c	Ink Type	<ul style="list-style-type: none"> The ink type registered on the IC chip is different from the ink type filled. 	<ul style="list-style-type: none"> Insert an ink IC chip for the correct ink type. "Replacing Ink"(P. 41)
61b	Ink supply	<ul style="list-style-type: none"> Ink cannot be supplied. 	<ol style="list-style-type: none"> Use [Maintenance] > [Ink Supply Maint.]. Turn off the main power and wait a while before turning back on. "Turning Off the Power"(P. 33)
627	Bottle set	<ul style="list-style-type: none"> The ink IC chip could not be read for a certain period of time. 	<ol style="list-style-type: none"> Check to confirm the ink IC chip was inserted correctly. Turn off the main power and wait a while before turning back on. "Turning Off the Power"(P. 33)
629	Expiration Near	<ul style="list-style-type: none"> The ink has expired. 	<ul style="list-style-type: none"> Replace with new ink or use up as quickly as possible. Printing is possible. "When Ink End is Displayed"(P. 40)
62a	Expiration Over	<ul style="list-style-type: none"> The ink is two months past its expiration date and cannot be used. 	<ul style="list-style-type: none"> Replace with new ink. Printing is not possible. "When Ink End is Displayed"(P. 40)
631	Ink Color	<ul style="list-style-type: none"> The ink color registered on the IC chip is different from the ink color filled. 	<ul style="list-style-type: none"> Insert an ink IC chip for the correct ink color. "Replacing Ink"(P. 41)
637	INK LEAK _	<ul style="list-style-type: none"> The ink leak sensor detected an ink leak. 	<ul style="list-style-type: none"> Contact your local dealer or our service office.

Error number	Message	Cause	Corrective action
650	NCU ^{*1} Connect	<ul style="list-style-type: none"> A problem was detected with the NCU^{*1} connection. 	<ul style="list-style-type: none"> Turn off the main power and wait a while before turning back on. "Turning Off the Power"(P. 33)
651	Replace NCU ^{*1}	<ul style="list-style-type: none"> A problem was detected with the nozzle clogging assessment. 	<ul style="list-style-type: none"> Clean the NCU^{*1}. "NCU (Option) Cleaning"(P. 97) Replace the NCU if the error does not clear. Contact your local dealer or our service office.
652	NCU ^{*1} Nzk Chk (Hw)	<ul style="list-style-type: none"> A problem was detected with the nozzle clogging assessment. 	<ul style="list-style-type: none"> Clean the NCU^{*1}. "NCU (Option) Cleaning"(P. 97)
653	NCU ^{*1} Nzk Chk (Mark)		
654	NCU ^{*1} Center Pos		
655	NCU ^{*1} Flush Pos		
656	NCU ^{*1} SN Adjst		
657	Replace NCU ^{*1} Ink Pad	<ul style="list-style-type: none"> The NCU^{*1} ink absorber is full. 	<ul style="list-style-type: none"> The NCU^{*1} ink absorber must be replaced. Contact your local dealer or our service office.
658	NCU ^{*1} Sensor Lv Low	<ul style="list-style-type: none"> The sensor's sensitivity is impaired. 	<ul style="list-style-type: none"> Clean the NCU^{*1}. "NCU (Option) Cleaning"(P. 97) Replace the NCU(Option) if the error does not clear. Contact your local dealer or our service office.
659	Less Supply	<ul style="list-style-type: none"> There is a problem with the ink supply. 	<ol style="list-style-type: none"> Check to confirm that there is sufficient ink in the ink pack for the path where the error occurred. Check to confirm that the ink pack for the path where the error occurred is not bent over. Use [Maintenance] > [Ink Supply Maint.] to check that the error clears.
65b	NCU ^{*1} Sens Adj Err H	<ul style="list-style-type: none"> Sensor sensitivity adjustment failed. 	<ul style="list-style-type: none"> Clean the NCU^{*1}. "NCU (Option) Cleaning"(P. 97) Replace the NCU(Option) if the error does not clear. Contact your local dealer or our service office.
65c	NCU ^{*1} Sens Adj Err L		
683	Wiper Near End	<ul style="list-style-type: none"> The remaining amount of cloth wiper is low. 	<ul style="list-style-type: none"> The cloth wiper will run out soon. Have a new cloth wiper ready.
684	Wiper End	<ul style="list-style-type: none"> The cloth wiper has run out. 	<ul style="list-style-type: none"> Replace with a new cloth wiper. "When Wiper End is Displayed"(P. 106)
702	Thermistor Connect	<ul style="list-style-type: none"> A problem was detected with the thermistor connection. 	<ul style="list-style-type: none"> Turn off the main power and wait a while before turning back on. "Turning Off the Power"(P. 33)
703	Heater Brk	<ul style="list-style-type: none"> A problem was detected with the heater temperature. 	

Error number	Message	Cause	Corrective action
706	UV Lamp Temp. High	<ul style="list-style-type: none"> The UV-LED unit became hot. 	<ul style="list-style-type: none"> If this occurs frequently, contact your local distributor, our sales office, or service center.
707	Head Heater Break	<ul style="list-style-type: none"> The head heater is defective. (The temperature does not rise even when heated beyond the stipulated duration.) 	<ul style="list-style-type: none"> Turn off the main power and wait a while before turning back on.  "Turning Off the Power"(P. 33)
70b	DRV OVHT	<ul style="list-style-type: none"> The UV-DRV PCB became hot. 	
710	Heater Temp Error	<ul style="list-style-type: none"> A problem was detected with the heater temperature. 	<ul style="list-style-type: none"> This error will be automatically resolved. If the error is not resolved, turn off the main power and wait a while before turning back on.
711	LED OVHT*	<ul style="list-style-type: none"> The UV-LED PCB became hot. 	<ul style="list-style-type: none"> Turn off the main power and wait a while before turning back on.  "Turning Off the Power"(P. 33)
715	Ink heater Thermistor	<ul style="list-style-type: none"> The ink heater thermistor cannot be read properly. 	
716	Ink Heater Temp	<ul style="list-style-type: none"> An ink heater temperature abnormality was detected. 	
717	InkHeater Brk	<ul style="list-style-type: none"> The ink heater is defective. (The temperature does not rise even when heated beyond the stipulated duration.) 	
71a	UV-DRV Fuse	<ul style="list-style-type: none"> A blown fuse on the UV-DRV PCB was detected. 	<ul style="list-style-type: none"> The fuse must be replaced. Contact your local dealer or our service office.
71e	Head Temp Error	<ul style="list-style-type: none"> A head temperature abnormality was detected. 	<ul style="list-style-type: none"> Turn off the main power and wait a while before turning back on.  "Turning Off the Power"(P. 33)
71f	Head Therm Break	<ul style="list-style-type: none"> The head thermistor cannot be read properly. 	
754	Ink Heater Temp	<ul style="list-style-type: none"> An ink heater temperature abnormality was detected for a specified time. 	
756	Head Temp Error	<ul style="list-style-type: none"> A head temperature abnormality was detected for a specified time. 	<ul style="list-style-type: none"> Turn off the main power and wait a while before turning back on.  "Turning Off the Power"(P. 33)
801	(C) OPCODE	<ul style="list-style-type: none"> A problem was detected with the main PCB. 	
802	(C) SWI		
803	(C)PFTCHABRT		
804	(C)DATAABRT		
806	FW/SIO bit	<ul style="list-style-type: none"> A communication error was detected between the boards. 	
808	FW/STP-MTR**	<ul style="list-style-type: none"> A problem was detected with the main PCB. 	

Error number	Message	Cause	Corrective action
80f	FW/SIO Vch	<ul style="list-style-type: none"> A communication error was detected between the boards. 	
811	FW/SIO read	<ul style="list-style-type: none"> A communication error was detected between the boards. 	
81b	FW/STACK OV	<ul style="list-style-type: none"> A problem was detected with the main PCB. 	
828	PRG ERR L*****		
901	Operation Error	<ul style="list-style-type: none"> The function is disabled due to an error. 	<ul style="list-style-type: none"> Check the error details. <ul style="list-style-type: none"> Media Undetected Ink Error Waste ink tank, etc.
902	Data Remain	<ul style="list-style-type: none"> Print (RIP) data was received. 	<ul style="list-style-type: none"> Switch to REMOTE mode and start printing or clear the data and abort printing.
90f	Print Area Short	<ul style="list-style-type: none"> The media is too small for the print. 	<ul style="list-style-type: none"> Replace with wider or longer media. If the printable area is reduced due to a shift in the origin, move the origin to increase the size of the printable area.
b49	PCB VHV FET[1]	<ul style="list-style-type: none"> A problem was detected with the PCB power supply. 	<p>Turn off the main power and wait a while before turning back on.  "Turning Off the Power"(P. 33)</p>
b5a	PCB MAIN- F***	<ul style="list-style-type: none"> A blown fuse on the ink PCB was detected. 	
b5c	Main PCB V05U	<ul style="list-style-type: none"> A problem was detected with the main PCB 5V power supply. 	
b5d	Main PCB V3R3U	<ul style="list-style-type: none"> A problem was detected with the main PCB 3.3V power supply. 	
b5e	Main PCB V1R5D	<ul style="list-style-type: none"> A problem was detected with the main PCB 1.5V power supply. 	
b5f	Main PCB V1R2U	<ul style="list-style-type: none"> A problem was detected with the main PCB 1.2V power supply. 	
b60	Main PCB V24	<ul style="list-style-type: none"> A problem was detected with the main PCB 24V power supply. 	
b6b	HEAD FFC	<ul style="list-style-type: none"> Head FFCs 1 to 4 (CN 11 to 14) are not connected correctly. 	
d1b	COM VOLT[1]	<ul style="list-style-type: none"> An error was detected in the LCU main E PCB supply voltage supply. 	<ul style="list-style-type: none"> Turn off the main power and wait a while before turning back on.  "Turning Off the Power"(P. 33)

* 1.NCU is optional.

SYSTEM HALT



- If a SYSTEM HALT number is displayed, turn off the main power and wait a while before turning back on.

Chapter 6 Appendix



This chapter

This chapter describes the machine specifications.

6.1 Specifications

Item		UJV200-130	UJV200-160
Print head	Type	On-demand piezo head	
	Specifications	One head with 400 nozzles × 8 rows each	
	Resolution	Y	600 dpi, 900 dpi, 1,200 dpi
X		600 dpi, 1,200 dpi	
Ink set	4-color	C, M, Y, K	
	4-color, W	C, M, Y, K, W	
	4-color, W, CL	C, M, Y, K, W, Cl	
Media	Type	Label paper (paper base), PVC sheet (not more than 0.25 mm in thickness, including laminating layer), fluorescent sheet, reflective sheet, window film, tarpaulin	
	Maximum printing width ^{*1}	1360 mm	1610 mm
	Maximum width	1370 mm	1620 mm
	Minimum width	210 mm	
	Thickness	Max. 1.0 mm	
	Roll external diameter ^{*2}	Max. 180 mm	
	Roll weight ^{*2, 3}	Max. 25 kg	
	Paper core internal diameter ^{*4}	2 inches or 3 inches	
	Printing face	Exterior/interior	
	Roll end	Taped or loosely affixed to paper core	
	Print margins	Left/right	15 mm (default), minimum: Left/right 5 mm
Top end		70 mm (default), minimum: Left/right 10 mm	
Bottom end		70 mm (default), minimum: Left/right 10 mm	
Distance accuracy ^{*5}	Absolute accuracy	±0.3 mm or ±0.3 % of specified distance, whichever is greater	
	Duplicability	±0.2 mm or ±0.1 % of specified distance, whichever is greater	
Perpendicularity	±0.25 mm/1,000 mm		
Media skew	Not more than 2.5 mm/10 m		
Printing gap	Manual, two settings (1.5, 2.0 mm)		
Clamp pressure	-		
Media cutting	Cutting precision (steps): Not more than 1.0 mm		
Origin alignment	LED pointer		
Ink supply	Bottle		
Waste Ink Tank	Bottle type (2,000 ml)		
Take-up unit	Selectable inside/outside winding		

Item		UJV200-130	UJV200-160
Media heater		PRE	
NCU (Nozzle clogging detection)		Options	
DAS2 (automatic correction function)		Provided	
Interior lighting		-	
UV unit		Provided	
Interface	Data transfer function	Ethernet 1000BASE-T ^{*7, 8} , USB 2.0 Hi-speed ^{*8, 9}	
Command		MRL-V	
Languages		English, Japanese, Chinese, Turkish, Portuguese, Spanish, Italian, Korean	
Noise levels	During standby	Not more than 55 dB (FAST-A, 1 m on all sides)	
	Continuous operation	Not more than 59 dB (FAST-A, 1 m on all sides)	
	Non-continuous operation	Not more than 70 dB (FAST-A, 1 m on all sides)	
Compliance with standards		VCCI-classA, FCC-classA, ETL compliant with IEC62368-1, CE marking (EMC Directive, Low Voltage Directive, Machinery Directive, RoHS Directive), CB certified, EnergyStar, RCM marking, KC certified, IEC62471	
Power supply specifications ^{*10}		Single phase AC100-120V±10%/11A, Single phase AC200-240V±10%/5.5A, 50/60±1Hz	
Power consumption	Maximum ^{*11}	Inlet 1	100 to 120 V AC: Max. 1,320 W, 200 to 240 V AC: Max. 1,320 W
		Inlet 2	-
	Standard	Inlet 1	550 W
		Inlet 2	-
	Minimum ^{*12}	Inlet 1	4.5 W or less
		Inlet 2	-
Installation environment ^{*13}	Permissible ambient temperature	20 to 30 °C	
	Relative humidity	35 to 65 %RH (no condensation)	
	Temperature range in which accuracy is guaranteed	20 to 25 °C	
	Temperature gradient	Not more than ±10 °C/h	
	Dust	0.15 mg/m ³ (typical office)	
	Maximum operating altitude	2000 m	

Item		UJV200-130	UJV200-160
External dimensions ^{*14}	Width	2,520 mm (2660 mm)	2,770 mm (2910 mm)
	Depth	748 mm (750 mm)	
	Height	1,405 mm (830 mm)	
Weight ^{*14}		155 kg (186 kg)	160 kg (197 kg)

*1. With setup menu margins set to the minimum (5 mm) on either side.

*2. External diameter and weight after winding media.

*3. Free of sagging due to weight.

*4. 3 inch only for high-speed printing.

*5. Excluding media size variation and initial loading fluctuations.

*6. Partial switch supported. Including clamp off.

*7. Printing is not possible if local guidance shows any speed other than "1000Mbps". Using a LAN Cable

*8. The print speed may be decreased depending on the connection environment or print data. Connecting a PC to the Product

*9. Data may be transferred to the machine too slowly, causing the carriage to pause at the left-hand or right-hand end during printing.

*10. Excluding options.

*11. Varies depending on print mode.

*12. In sleep.

*13. Ink ejection consistency may decrease in conditions outside this range.

*14. Size excluding ink bottles. The figures in parentheses indicate package dimensions.

6.2 LICENSE Library

Mimaki printer Firmware

Copyright ©2020 MIMAKI ENGINEERING CO.,LTD. All rights reserved.

This product contain open source software listed in the tables below.

Component	License
StarterWare for ARM® based TI Sitara Processors	BSD-TI

The following license terms and conditions shall apply to the open source software listed in the table above:

BSD-TI

Copyright (C) 2010 Texas Instruments Incorporated - <http://www.ti.com/>

Redistribution and use in source and binary forms, with or without modification, are permitted provided that the following conditions are met:

1. Redistributions of source code must retain the above copyright notice, this list of conditions and the following disclaimer.
2. Redistributions in binary form must reproduce the above copyright notice, this list of conditions and the following disclaimer in the documentation and/or other materials provided with the distribution.
3. Neither the name of Texas Instruments Incorporated nor the names of its contributors may be used to endorse or promote products derived from this software without specific prior written permission.

THIS SOFTWARE IS PROVIDED BY THE COPYRIGHT HOLDERS AND CONTRIBUTORS "AS IS" AND ANY EXPRESS OR IMPLIED WARRANTIES, INCLUDING, BUT NOT LIMITED TO, THE IMPLIED WARRANTIES OF MERCHANTABILITY AND FITNESS FOR A PARTICULAR PURPOSE ARE DISCLAIMED. IN NO EVENT SHALL THE COPYRIGHT OWNER OR CONTRIBUTORS BE LIABLE FOR ANY DIRECT, INDIRECT, INCIDENTAL, SPECIAL, EXEMPLARY, OR CONSEQUENTIAL DAMAGES (INCLUDING, BUT NOT LIMITED TO, PROCUREMENT OF SUBSTITUTE GOODS OR SERVICES; LOSS OF USE, DATA, OR PROFITS; OR BUSINESS INTERRUPTION) HOWEVER CAUSED AND ON ANY THEORY OF LIABILITY, WHETHER IN CONTRACT, STRICT LIABILITY, OR TORT (INCLUDING NEGLIGENCE OR OTHERWISE) ARISING IN ANY WAY OUT OF THE USE OF THIS SOFTWARE, EVEN IF ADVISED OF THE POSSIBILITY OF SUCH DAMAGE.

Index

A

Adjust Waste Ink Volume	115
Air PG	85, 124
Auto Cleaning	85
Auto Maint.	84
Auto Nozzle Recovery	84
Auto Power-off.....	87
Auto Power-on.....	87
Auto Remote	88
Auto-correction	31
Auto-correction (DAS)	80
Auto-correction (DAS2)	128

B

Bottle cap	41, 42, 44
------------------	------------

C

Cancel	29
Cap	26, 93, 94, 109
Cap absorber.....	111
Cap Replacement.....	83
Capping Use Days	90
Carriage.....	24, 26, 29, 83, 93, 95
Carriage Out.....	83
Clamp lever	24, 25
Cleaning	67, 83
Cloth wiper	96
Color profile	38
Custody Wash	83, 104
Cutting slot	26

D

DAS (Dot Adjustment System)	93
DAS2: Dot Adjustment System2	80
Delete MediaInfo	82
Detail Setting	81
DISCLAIMERS	5
Display.....	29, 30
Display language.....	89

Drop.PosCorrect.....	31, 50, 71, 80
Dropouts.....	124
DAS (automatic correction function) / Sheet width sensor.....	98

E

Ejection failures.....	65, 67, 83, 86, 109, 120
[END/POWER] key.....	28, 29, 33
[ENTER] key.....	29
Environment Setting Menu.....	89
Error.....	29, 127
Error History.....	90

F

FCC.....	6
Feed Comp.....	31, 50, 69, 80
Feed Comp.(pull-back).....	80
Feed Speed.....	82
Feeding Before Cut.....	88
Feeding unit.....	25
[FUNCTION] key.....	29, 31
Function Setting Menu.....	87

G

Grit roller.....	24, 27
------------------	--------

H

Head Cleaning.....	29
Head height.....	51
Heater.....	25, 28, 81, 125
Height adjustment lever.....	51
Opening/closing cover.....	24

I

Ink discharge channel.....	93, 99
Ink End.....	40
Ink error.....	30
INK NEAR-END.....	40
Ink status.....	30
Ink Supply Maint.....	85
Inlet.....	25, 32
Installation guide.....	38, 39
Installation Space.....	17

Interference	5
interlock	18
Interval Wiping.....	85
Ionizer.....	81
<hr/> J <hr/>	
Jam sensor	24, 93, 102
[JOG] key	29
Judgment Condition	84
<hr/> K <hr/>	
Key Buzzer	89
KeyLife	89
<hr/> L <hr/>	
LAN cable	25, 35
LAN port	25
LANGUAGE	89
Light-blocking cover	41, 125
List.....	90
Local guidance	31
LOCAL mode.....	29, 30
Logical Seek.....	87
<hr/> M <hr/>	
Machine Status Menu.....	90
Main power switch.....	25, 28, 32
Maintenance cover	24
Maintenance liquid absorber	111
Maintenance Menu.....	83
MAPS: Mimaki Advanced Pass System.....	81
Margin	88
Media.....	52
Media cutter.....	24, 93, 100, 114
Media feed.....	29
Media holder.....	93, 101, 112
Media Information.....	81
Media Name Change	82
Media Remain	81
Media Sensor	25, 27, 93, 99
Media Setting Menu	80
Media stopper.....	55

Media Width	81
MENU mode	30
Mimaki driver	38
MRA (Mimaki Remote Access).....	89

N

NCU (Nozzle Check Unit).....	26, 97
Network	89
NOT-READY mode	30
Nozzle Check	84, 86
Nozzle clogging	67, 86
Nozzle Deflection	67
Nozzle Recovery	84, 86
Nozzle Wash	83, 123

O

Operating Panel	24, 29
-----------------------	--------

P

PIN code.....	89
Pinch roller	24, 27
Platen	24, 26, 93, 102
Power cable.....	32
Power outlet	32
Power plug	32
Power Setting	87
Preheater.....	64
Print Area	90
Print Length	90
Print Maint.	84
Print origin	75
Printing Check.....	84
Pump Tube Cleaning.....	99

R

RasterLink	38, 39, 73, 74, 88
Receive buffer	77
Reference guide	74
Remaining ink.....	30
Remote Control	89
REMOTE mode	29, 30
Replace Wiper	83, 90, 106

Roll holder 56, 57

S

[SEL] key 29

Sensor sensitivity 127, 135

Smoothing Level (Color)..... 81

Smoothing Level (Spot)..... 81

Space Btwn PP. 88

Space Feed Mode 88

Station 24, 26

Station Maint. 83

Status lamp 29

Switching hub 35

Symbol 7

SYSTEM HALT 29

T

Take-up SW 87

Take-up unit 24, 53, 87

Test Printing 29, 65, 83

Time Set 89

Torque limiter 54

U

Unit Setting 89

Usage 90

USB interface cable 25, 36

USB port 25

Use Time 90

UV AdjVal 80

UV Lamp 90

UV mode 80

UV-LED lamp 80

V

Vacuum Fan 81

Version 90

View Feed 88

W

Warning Label 19

Waste Ink Tank 24, 85, 90, 93, 115, 116

White ink.....	66
White Maintenance.....	85
WhiteSpace Setting.....	88
Wiper.....	26, 83, 126

Operation manual

April, 2026

MIMAKI ENGINEERING CO.,LTD.

2182-3 Shigeno-otsu, Tomi-shi, Nagano 389-0512 JAPAN

D203918-11-30042026

